

4-Star Trailers Owner's Manual



4-Star Trailers

GOOSENECK AND BUMPER PULL TRAILERS

^WARNING

This User's Manual contains safety information and instructions for your trailer.

You must read this manual before loading or towing your trailer.

You must follow all safety precautions and instructions.

**4-Star Trailers
10000 N.W. 10th Street
Oklahoma City, OK 73127
405-324-7827 Phone
405-324-7625 Facsimile**

Table of Contents
GOOSENECK AND BUMPER PULL TRAILERS

1.	INTRODUCTION / WARRANTY INFORMATION	1
1.1	INTRODUCTION	1
1.2	MANUFACTURERS WARRANTY	1
1.2.1	Warranty Procedure Guide	1
2.	GENERAL SAFETY INFORMATION	2
2.1	SAFETY ALERT SYMBOLS AND SIGNAL WORDS	2
2.2	MAJOR HAZARDS	2
2.2.1	Improper Sizing Of The Trailer To The Tow Vehicle	2
2.2.2	Driving Too Fast	2
2.2.3	Failure to Adjust Driving Behavior When Towing a Trailer	3
2.2.4	Trailer Not Properly Coupled to the Hitch	3
2.2.5	Proper Use of Safety Chains	4
2.2.6	Proper Connection of Breakaway Brake	4
2.2.7	Matching Trailer and Hitch	4
2.2.8	Worn Tires, Loose Wheels and Lug Nuts	4
2.2.9	Improper Loading	5
2.2.10	Unsafe Load Distribution	5
2.2.11	Shifting Cargo	5
2.2.12	Inappropriate Cargo	6
2.2.13	Inoperable Brakes, Lights or Mirrors	6
2.2.14	Hazards From Modifying Your Trailer	6
2.2.15	Hazards to Horses (Horse Trailer)	7
2.2.16	Hazards to Livestock (Livestock Trailer)	7
2.2.17	Hazards from Accessories	8
2.2.18	Safety Warning Labels on Your Trailer	9
2.2.19	Trailer Towing Guide	11
2.2.20	Reporting Safety Defects	13
2.3	SAFE TRAILER TOWING GUIDELINES	13
3.	TIRE SAFETY INFORMATION	14
3.1	TRAILER TIRE INFORMATION	14
3.2	STEPS FOR DETERMINING CORRECT LOAD LIMIT – TRAILER	15
3.2.1	Trailers 10,000 Pounds GVWR or Less	15
3.2.2	Trailers Over 10,000 Pounds GVWR	15
3.3	STEPS FOR DETERMINING CORRECT LOAD LIMIT – TOW VEHICLE	16
3.4	GLOSSARY OF TIRE TERMINOLOGY	16
3.5	TIRE SAFETY - EVERYTHING RIDES ON IT	18
3.5.1	Safety First–Basic Tire Maintenance	19
3.5.2	Finding Your Vehicle's Recommended Tire Pressure and Load Limits	19
3.5.3	Understanding Tire Pressure and Load Limits	19
3.5.4	Checking Tire Pressure	19
3.5.5	Steps for Maintaining Proper Tire Pressure	19
3.5.6	Tire Size	20
3.5.7	Tire Tread	20
3.5.8	Tire Balance and Wheel Alignment	20
3.5.9	Tire Repair	20
3.5.10	Tire Fundamentals	20
3.5.10.1.	Information on Passenger Vehicle Tires	20
3.5.10.2.	UTQGS Information	21
3.5.10.3.	Additional Information on Light Truck Tires	21
3.5.11	Tire Safety Tips	22
4.	COUPLING TO THE TOW VEHICLE	23

Table of Contents
GOOSENECK AND BUMPER PULL TRAILERS

4.1	USE AN ADEQUATE TOW VEHICLE AND HITCH	23
4.1.1	Trailer Information	23
4.1.2	Tow Vehicle	24
4.2	COUPLING AND UNCOUPLING THE TRAILER	25
4.2.1	Various Coupler Designs	25
4.3	BUMPER PULL TRAILERS	25
4.3.1	Before Coupling The Trailer To The Tow Vehicle.....	26
4.3.2	Prepare The Coupler And Hitch Ball	26
4.3.3	Couple The Trailer To The Tow Vehicle	27
4.3.4	Rig The Safety Chains	27
4.3.5	Attach And Test Breakaway Brake System	27
4.3.6	Connect 7-Pin Electrical Connector.....	28
4.3.7	Uncoupling The Bumper Pull Trailer.....	29
4.4	GOOSENECK TRAILER WITH BALL COUPLER.....	29
4.4.1	Before Coupling The Trailer To The Tow Vehicle.....	30
4.4.2	Prepare The Coupler And Gooseneck Ball	30
4.4.3	Couple The Trailer To The Tow Vehicle	31
4.4.4	Rig The Safety Chains	31
4.4.5	Attach And Test The Breakaway Brake System	32
4.4.6	Connect 7-Pin Electrical Connector.....	33
4.4.7	Uncoupling The Gooseneck Trailer With Ball Coupler.....	33
4.5	GOOSENECK TRAILER WITH KINGPIN	34
4.5.1	Before Coupling The Trailer To The Tow Vehicle.....	34
4.5.2	Prepare The Fifth Wheel And Kingpin	34
4.5.3	Couple The Trailer To The Tow Vehicle	35
4.5.4	Attach And Test The Breakaway Brake System	36
4.5.5	Connect 7-Pin Electrical Cable	36
4.5.6	Uncoupling The Gooseneck Trailer With Kingpin.....	37
4.6	ADJUST GOOSENECK COUPLER OR KINGPIN HEIGHT	38
5.	LOADING THE TRAILER.....	39
5.1	TONGUE WEIGHT	39
5.2	CHECKING TONGUE WEIGHT	40
5.3	SECURING THE CARGO.....	40
5.4	LOADING AN ENCLOSED TRAILER	40
5.4.1	Preparing Trailer For Loading.....	41
5.4.2	Loading the Enclosed Trailer.....	41
5.5	LOADING HORSE TRAILER.....	41
5.5.1	Preparing Horse Trailer For Loading.....	42
5.5.2	Loading Horse Trailer	42
5.6	LOADING LIVESTOCK	44
5.6.1	Preparing Livestock Trailer For Loading.....	44
5.6.2	Loading Livestock Trailer	44
6.	CHECKING THE TRAILER BEFORE AND DURING EACH TOW	46
6.1	PRE-TOW CHECKLIST	46
6.2	MAKE REGULAR STOPS	46
7.	BREAKING-IN A NEW TRAILER.....	47
7.1	RETIGHTEN LUG NUTS AT FIRST 10, 25 & 50 MILES.....	47
7.2	ADJUST BRAKE SHOES AT FIRST 200 MILES.....	47
7.3	SYNCHRONIZING THE BRAKE SYSTEMS	47
7.4	TIRE PRESSURE.....	47
8.	ACCESSORIES	48

Table of Contents
GOOSENECK AND BUMPER PULL TRAILERS

8.1	ACCESSORY BATTERY	48
8.2	LIVESTOCK GATES	48
8.3	REAR RAMP OVER DOORS	49
8.4	SIDE RAMP	50
8.5	EGRESS WINDOW.....	50
8.6	DROP DOWN FEED DOORS	51
9.	INSPECTION, SERVICE & MAINTENANCE.....	53
9.1	INSPECTION, SERVICE & MAINTENANCE SUMMARY CHARTS	53
9.2	INSPECTION AND SERVICE INSTRUCTIONS	55
9.2.1	Axle Bolts, Frame, Suspension, & Structure.....	55
9.2.2	Trailer Structure	55
9.2.2.1.	Fasteners And Frame Members	55
9.2.2.2.	Welds	55
9.2.2.3.	Center Gate Latch.....	55
9.2.3	Drop Ramp Torsion Springs.....	56
9.2.4	Slide-Outs	56
9.2.5	Trailer Brakes	56
9.2.5.1.	Brake Shoes And Drums	56
9.2.5.2.	Manually Adjusting Brake Shoes	56
9.2.5.3.	Brakes, Electric	56
9.2.5.4.	Brakes, Hydraulic (vacuum, air or electric operated).....	57
9.2.6	Trailer Connection to Tow Vehicle	57
9.2.6.1.	Bumper Pull Coupler and Ball	57
9.2.6.2.	Gooseneck Coupler and Ball.....	57
9.2.6.3.	Gooseneck Fifth Wheel and Kingpin	58
9.2.7	Landing Leg or Jack	58
9.2.8	Lights and Signals.....	58
9.2.9	Accessory Battery	58
9.2.10	Tires	58
9.2.11	Wheel Rims.....	59
9.2.12	Wheel Bearings	59
9.2.12.1.	Unsealed Bearings (Hubs).....	59
9.2.13	Lug Nuts (Bolts).....	59

1. INTRODUCTION / WARRANTY INFORMATION

1.1 INTRODUCTION

We would like to sincerely thank you for your purchase of a 4-Star Trailer. At 4-Star Trailers we have been building trailers since 1984, and since day one, we have put the utmost care in building the finest quality aluminum trailer in the market. We value each and every customer who purchases a 4-Star Trailer. Our dedication to customer safety and satisfaction ensures that every trailer we produce reaches the level of durability and innovation to be a 4-Star Trailer. We realize that every person is different, with different needs and interests, so we focus on each customer as an individual and make sure to customize every trailer to match the personality of its owner. To own a 4-Star Trailer is to tell the world that you belong to an association of people linked by their individuality, and their desire to experience and own the best.

The safety of your cargo, whether it is animal or otherwise, is the highest priority in our designs. However, as a trailer owner, it is your responsibility to be familiar with your new trailer and follow the instructions to ensure that you enjoy many years of safe travel with your 4-Star Trailer. This owner's manual explains the operation of the basic 4-Star Trailer. Read this manual before using your 4-Star Trailer and follow all safety instructions. This manual does not cover the living quarters, if your trailer is so equipped. Therefore you must read, understand, and follow the instructions given by your living quarters package, tow vehicle, and trailer hitch manufacturers, as well as the instructions in this owners manual. Keep all manuals provided with your trailer in a safe place in the trailer at all times.

Our trailers are built with various components produced by various manufacturers. Some of these items have separate instruction manuals. Where this manual indicates that you should read another manual, and you do not have that manual, call 4-Star Trailers at (405) 324-7827 for assistance.

1.2 MANUFACTURERS WARRANTY

Refer to separately supplied Manufacturers Warranty sheet accompanied with the information packet.

1.2.1 Warranty Procedure Guide

Making a claim:

Review the 4-STAR TRAILERS, INC. warranty statement for the product in question, If the components are within the stated coverage time period,

Record the following information:

VIN number of trailer. (located on the VIN sticker on the street side front of the trailer also stamped in the aluminum on the gooseneck street side of the trailer)

Date trailer was originally purchased and the name of the Dealer purchased from.

Part number and/or description of the failed or problem component and photo's of failed items.

Warranty starting date:

The starting date shall be determined by the date of sale to the original purchaser.

Warranty Policy on Returned Items Manufactured by 4-Star and/or Vendors:

Items manufactured by 4-Star Trailers, Inc.

1. Call the Dealer from which you purchased your trailer and forward earlier recorded information along with description of issue.
2. The Dealer will contact 4-Star and obtain a claim number/authorization prior to repairs being performed.
3. Items manufactured by 4-Star may require the item/items to be returned to 4-Star's factory. Warranty claims for **(Structural Repairs)** will require the trailer to be returned and repaired exclusively at 4-Star's factory, transportation charges to and/or from 4-Star's factory will not be provided or reimbursed by 4-Star.

Items NOT manufactured by 4-Star Trailers, Inc.

Components not manufactured by 4-Star are covered only by the warranties extended by the manufacturers of such components, and not by 4-Star. Such non-warranted components included but not limited to: tires, wheels, coupler, jacks hub caps, axles, suspension components, hubs, drums, brakes and all parts associated therewith. Request for warranty adjustments on these items shall be made directly to their manufacturers.

1. Call the Dealer from which you purchased your trailer and forward information along with photo's of failed items, the dealer will notify 4-Star of the failed vendor item and will obtain information on the vendors name and/or continued address and/or authorization for repairs.
2. Vendors require the return of the item/items with 10 days from the issuance of the Claim

Introduction/Warranty Information

No. (Claims with items returned, exceeding 30 days will automatically be closed without notification) please allow approximately two weeks for the evaluation and determination of the claim.

3. All return item/items must be pre-paid (COD will not be accepted).
4. Replacement items can be requested when filing a claim. However, replacement parts will be invoiced, including freight. Reimbursement for the replacement item will be dependent upon the evaluation and determination of the claim, Freight will be reimbursed for standard delivery service only.

Warranty work should not begin until 4-Star Trailers, Inc. and or Vendor issues a written approval for parts replacement, repairs and/or labor allowance if applicable.

2. GENERAL SAFETY INFORMATION

2.1 SAFETY ALERT SYMBOLS AND SIGNAL WORDS

An Owner's Manual that provides general trailer information cannot cover all of the specific details necessary for the proper combination of every trailer, tow vehicle and hitch. Therefore, you must read, understand and follow the instructions given by the tow vehicle and trailer hitch manufacturers, as well as the instructions in this manual.

Our trailers are built with components produced by various manufacturers. Some of these items have separate instruction manuals. Where this manual indicates that you should read another manual, and you do not have that manual, call 4-Star Trailers at 405-324-7827 for assistance.

The safety information in this manual is denoted by the safety alert symbol: ^

The level of risk is indicated by the following signal words.

^Danger

DANGER – Immediate hazards which **WILL** result in severe personal injury or death if the warning is ignored.

^WARNING

WARNING – Hazards or unsafe practices which **COULD** result in severe personal injury or death if the warning is ignored.

^Caution

CAUTION – Hazards or unsafe practices which could result in minor or moderate injury if the warning is ignored.

^Notice

NOTICE – Practices that could result in damage to the trailer or other property.

2.2 MAJOR HAZARDS

Loss of control of the trailer or trailer/tow vehicle combination can result in death or serious injury. The most common causes for loss of control of the trailer are:

- Improper sizing the trailer for the tow vehicle, or vice versa.
- Excessive Speed: Driving too fast for the conditions.
- Failure to adjust driving behavior when towing a trailer.
- Overloading and/or improper weight distribution.
- Improper or mis-coupling of the trailer to the hitch.
- Improper braking and steering under sway conditions.
- Not maintaining proper tire pressure.
- Not keeping lug nuts tight.

2.2.1 Improper Sizing Of The Trailer To The Tow Vehicle.

Trailers that weigh too much for the towing vehicle can cause stability problems, which can lead to death or serious injury. Furthermore, the additional strain put on the engine and drive-train may lead to serious tow vehicle maintenance problems. For these reasons the maximum towing capacity of your towing vehicle should not be exceeded. The towing capacity of your tow vehicle, in terms of maximum Gross Trailer Weight (GTW) and maximum Gross Combined Weight Rating (GCWR) can be found in the tow vehicles Owner's Manual.

^Danger

Use of a hitch with a load rating less than the load rating of the trailer can result in loss of control and may lead to death or serious injury.

Use of a tow vehicle with a towing capacity less than the load rating of the trailer can result in loss of control, and may lead to death or serious injury.

Be sure your hitch and tow vehicle are rated for the Gross Vehicle Weight Rating (GVWR) of your trailer.

2.2.2 Driving Too Fast

With ideal road conditions, the maximum recommended speed for safely towing a trailer is 60

mph. If you drive too fast, the trailer is more likely to sway, thus increasing the possibility for loss of control. Also your tires may overheat, thus increasing the possibility of a blowout.

^WARNING

Driving too fast for conditions can result in loss of control and cause death or serious injury.

Decrease your speed as road, weather and lighting conditions deteriorate.

2.2.3 Failure to Adjust Driving Behavior When Towing a Trailer

When towing a trailer, you will have decreased acceleration, increased stopping distance, and increased turning radius (which means you must make wider turns to keep from hitting curbs, vehicles, and anything else that is on the inside corner). Furthermore, the trailer will change the handling characteristics of your towing vehicle, making it more sensitive to steering inputs and more likely to be pushed around in windy conditions or when being passed by large vehicles. In addition, you will need a longer distance to pass, due to slower acceleration and increased length. With these caveats in mind:

- Be alert for slippery conditions. You are more likely to be affected by slippery road surfaces when driving a tow vehicle with a trailer, than driving a tow vehicle without a trailer.
- Anticipate the trailer “swaying.” Swaying can be caused by excessive steering, wind gusts, roadway edges, or by the trailer reaction to the pressure wave created by passing trucks and busses.
- When encountering trailer sway take your foot off the gas, and steer as little as possible in order to stay on the road. Use small “trim-like” steering adjustments. Do not attempt to steer out of the sway; you’ll only make it worse. Also do not apply the tow vehicle brakes to correct trailer swaying. On the other hand, application of the trailer brakes alone will tend to straighten out the combination, especially when going downhill.
- Check rearview mirrors frequently to observe the trailer and traffic.
- Use lower gear when driving down steep or long grades. Use the engine and transmission as a brake. Do not ride the brakes, as they can overheat and become ineffective.
- Be aware of your trailer height, especially when approaching bridges, roofed areas and around trees.

2.2.4 Trailer Not Properly Coupled to the Hitch

It is critical that the trailer be securely coupled to the hitch and that the safety chains and emergency breakaway brake lanyard are correctly attached. Uncoupling may result in death or serious injury to you and to others.

^WARNING

Proper selection and condition of the coupler and hitch are essential to safely towing your trailer. A loss of coupling may result in death or serious injury.

- **Be sure the hitch load rating is equal to or greater than the load rating of the coupler.**
- **Be sure the hitch size matches the coupler size**
- **Observe the hitch for wear, corrosion and cracks before coupling. Replace worn, corroded or cracked hitch components before coupling the trailer to the tow vehicle.**
- **Be sure the hitch components are tight before coupling the trailer to the tow vehicle.**

^WARNING

An improperly coupled trailer can result in death or serious injury.

Do not move the trailer until:

- **The coupler is secured and locked to hitch;**
- **The safety chains are secured to the tow vehicle; and**
- **The trailer jack(s) are fully retracted.**

Do not tow the trailer on the road until:

- **Tires and wheels are checked;**
- **The trailer brakes are checked;**
- **The breakaway switch is connected to the tow vehicle;**
- **The load is secured to the trailer; and**
- **The trailer lights are connected and checked.**

2.2.5 Proper Use of Safety Chains

If your trailer comes loose from the hitch for any reason, we have provided safety chains so that control of the trailer can still be maintained

^WARNING

Improper rigging of the safety chains can result in loss of control of the trailer and tow vehicle, leading to death or serious injury, if the trailer uncouples from the tow vehicle.

- Fasten chains to frame of tow vehicle. Do not fasten chains to any part of the hitch unless the hitch has holes or loops specifically for that purpose.
- Cross chains underneath hitch and coupler with enough slack to permit turning and to hold tongue up, if the trailer comes loose.

2.2.6 Proper Connection of Breakaway Brake

If equipped with brakes, your trailer will be equipped with a breakaway brake system that can apply the brakes on your trailer if your trailer comes loose from the hitch for any reason. You will have a separate set of instructions for the breakaway brake if your trailer is so equipped. The breakaway brake system, including battery, must be in good condition and properly rigged to be effective.

^WARNING

An ineffective or inoperative breakaway brake system can result in a runaway trailer, leading to death or serious injury if the coupler or hitch fails.

The breakaway cable must be connected to the tow vehicle, and NOT to any part of the hitch.

Before towing the trailer, test the function of the breakaway brake system. If the breakaway brake system is not working, do not tow the trailer. Have it serviced or repaired.

2.2.7 Matching Trailer and Hitch

^Danger

Use of a hitch with a load rating less than the load rating of the trailer can result in loss of control and may lead to death or serious injury.

Use of a tow vehicle with a towing capacity less than the load rating of the trailer can result in loss of control, and may lead to death or serious injury.

Be sure your hitch and tow vehicle are rated for the Gross Vehicle Weight Rating (GVWR) of your trailer.

2.2.8 Worn Tires, Loose Wheels and Lug Nuts

Just as with your tow vehicle, the trailer tires and wheels are important safety items. Therefore, it is essential to inspect the trailer tires before each tow.

If a tire has a bald spot, bulge, cut, cracks, or is showing any cords, replace the tire before towing. If a tire has uneven tread wear, take the trailer to a dealer service center for diagnosis. Uneven tread wear can be caused by tire imbalance, axle misalignment or incorrect inflation.

Tires with too little tread will not provide adequate frictional forces on wet roadways and can result in loss of control, leading to death or serious injury.

Improper tire pressure causes increased tire wear and may reduce trailer stability, which can result in a tire blowout or possible loss of control. Therefore, before each tow you must also check the tire pressure. Remember, the proper tire pressure is listed on the Certification / VIN label, normally mounted on front left side of the trailer, and should be checked when tires are cold. Allow 3 hours cool-down after driving as much as 1 mile at 40 mph before checking tire pressure.

^WARNING

Improper tire pressure can result in a blowout and loss of control, which can lead to death or serious injury.

Be sure tires are inflated to pressure indicated on sidewall before towing trailer.

The tightness of the lug nuts is very important in keeping the wheels properly seated to the hub. Before each tow, check to make sure they are tight.

^WARNING

Metal creep between the wheel rim and lug nuts will cause rim to loosen and could result in a wheel coming off, leading to death or serious injury.

Tighten lug nuts before each tow.

The proper tightness (torque) and tightening sequence for lug nuts is listed in Section 9.2.13 in the "Inspection and Service Instructions" chapter of this manual. Use a torque wrench to tighten the lug nuts.

Lug nuts are also prone to loosen after first being assembled. When driving a new trailer (or after wheels have been remounted), check to make sure they are tight after the **first** 10, 25 and 50 miles of driving and before each tow thereafter.

Failure to perform this check can result in a wheel separating from the trailer and a crash, leading to death or serious injury.

^WARNING

Lug nuts are prone to loosen after initial installation, which can lead to death or serious injury.

Check lug nuts for tightness on a new trailer or when wheel(s) have been remounted after the first 10, 25 and 50 miles of driving.

^WARNING

Improper lug nut torque can cause a wheel separating from the trailer, leading to death or serious injury.

Be sure lug nuts are tight before each tow.

2.2.9 Improper Loading

The total weight of the load you put in or on the trailer, plus the empty weight of the trailer itself, must not exceed the trailer's Gross Vehicle Weight Rating (GVWR). If you do not know the empty weight of the trailer plus the cargo weight, you must weigh the loaded trailer at a commercial scale. In addition, you must distribute the load in the trailer such that the load on any axle does not exceed the Gross Axle Weight Rating (GAWR). If your trailer is equipped with a Tire & Loading Information Placard, mounted next to the

Certification / VIN label, the cargo capacity weight stated on that placard is only a close estimate. The GVWR and GAWR's are listed on the Certification / VIN label mounted on the front left side of the trailer.

Error! Not a valid filename.

2.2.10 Unsafe Load Distribution

Improper front / rear load distribution can lead to poor trailer sway stability or poor tow vehicle handling. Poor trailer sway stability results from tongue weights that are too low, and poor tow vehicle stability results from tongue weights that are too high. Refer to Chapter heading "Loading the Trailer" for more information.

In the table below, the second column shows the rule of thumb percentage of total weight of the trailer plus its cargo (Gross Trailer Weight, or "GTW") that should appear on the tongue of the trailer. For example, a trailer with a gooseneck hitch, with a loaded weight of 12,000 pounds, should have 20-25% of 12,000 pounds (2400-3000 lbs.) on the gooseneck.

After loading, be sure to check that none of the axles are overloaded.

Error! Not a valid filename.

Uneven left / right load distribution can cause tire, wheel, axle or structural failure. Be sure your trailer is evenly loaded left / right. Towing stability also depends on keeping the center of gravity as low as possible.

^WARNING

Improper tongue weight (load distribution) can result in loss of control of the trailer, leading to death or serious injury.

Make certain that tongue weight is within the allowable range.

Be sure to:

- **Distribute the load front-to-rear to provide proper tongue weight (see chart);**
- **Distribute the load evenly, right and left, to avoid tire overload; and**
- **Keep the center of gravity low.**

2.2.11 Shifting Cargo

Since the trailer "ride" can be bumpy and rough, you must secure your cargo so that it does not shift while the trailer is being towed.

^WARNING

Shifting cargo can result in loss of control of the trailer, and can lead to death or serious injury.

Tie down all loads with proper sized fasteners, ropes, straps, etc.

If the door latch is equipped with a catch that has a hole for a linchpin, use a linchpin to prevent the door latch from opening.

^WARNING

If the door opens, your cargo may be ejected onto the road, resulting in death or serious injury to other drivers.

Always secure the door latch after closing. Place a linchpin in the catch.

2.2.12 Inappropriate Cargo

Your trailer may be designed for specific cargo, for example, only for horses. If your trailer is designed for specific cargo, only carry that cargo in the trailer. A trailer must not be used to carry certain items, such as people, containers of hazardous substances or containers of flammable substances. A trailer not designed and equipped with a living quarters should only be used for transportation of its intended cargo.

^WARNING

Do not transport people inside the trailer, even if it has living quarters. The transport of people puts their lives at risk and may be illegal.

^WARNING

Do not sleep in a trailer not equipped with living quarters while operating a portable heater, generator or other fuel burning appliances as carbon monoxide poisoning can occur and may result in death or serious injury.

A trailer not designed with living quarters should only be used for transportation of its intended cargo.

^WARNING

Do not transport flammable, explosive, poisonous or other dangerous materials in your trailer.

2.2.13 Inoperable Brakes, Lights or Mirrors

Be sure that the electric brakes and all of the lights on your trailer are functioning properly before towing your trailer. Electric brakes and lights on a trailer are controlled via a connection to the tow vehicle, generally a multi-pin electrical connector. Check the trailer tail lights by turning on your tow vehicle headlights. Check the trailer brake lights by having someone step on the tow vehicle brake pedal while you look at trailer lights. Do the same thing to check the turn signal lights.

If your trailer has electric brakes, your tow vehicle will have an electric brake controller that sends power to the trailer brakes. Before towing the trailer on the road, you must operate the brake controller while trying to pull the trailer in order to confirm that the electric brakes operate. While towing the trailer at less than 5 mph, manually operate the electric brake controller in the tow vehicle cab. You should feel the operation of the trailer brakes.

^WARNING

Improper electrical connection between the tow vehicle and the trailer will result in inoperable lights and electric brakes, and can lead to collision.

Before each tow:

- Check that the taillights, brake lights and turn signals work
- Check that the electric brakes work by operating the brake controller inside the tow vehicle

Standard mirrors usually do not provide adequate visibility for viewing traffic to the sides and rear a towed trailer. You must provide mirrors that allow you to safely observe approaching traffic.

2.2.14 Hazards From Modifying Your Trailer

Essential safety items can be damaged by altering your trailer. Even simply driving a nail or screw to hang

something can damage an electrical circuit or other feature of the trailer.

Before making any alteration to your trailer, contact your dealer or 4-Star Trailers at 405-324-7827 and describe the alteration you are contemplating. Alteration of the trailer may void the warranty. Alteration of the trailer structure or modification of mechanical, electrical, plumbing, heating or other systems on your trailer must be performed only by qualified technicians who are familiar with the system as installed on your trailer.

2.2.15 **Hazards to Horses (Horse Trailer)**

Before hauling a horse, you must be aware of its temperament.

The layout of a horse trailer is designed to safely contain your horse. The trailer is equipped with stall dividers and tie rings to secure the horse, and has a rubber floor mat to keep shod horses from slipping on the metal underfloor. Restraining a horse without using a combination of a tie-strap and stall dividers may result in serious injury or death to the horse.

Before loading your horse, inspect the interior of the horse trailer to insure that no hazards are present. Read the "Loading Horse Trailer" section on page 41 of this manual for specific instructions regarding trailering of horses.

^WARNING
<p>When a horse is frightened, it is capable of inflicting serious injury or death to a human handler.</p> <p>Know your horse's temperament before attempting to trailer it.</p> <p>Handling a horse that is not trailer-acclimated may result in injury or death, or damage to your trailer.</p> <p>Do not haul an unbroken horse in this trailer.</p> <p>Horses must have a halter.</p>

^Caution
<p>Failure to secure a horse using a tie strap may result in its serious injury or death.</p>

^Caution
<p>The trailer interior may contain hazards to a horse that can result in its serious injury or death.</p> <p>Before loading a horse, inspect the trailer interior and adjust or repair all loose and protruding features such as handles, loose or broken parts of the trailer, etc.</p> <p>Before towing trailer:</p> <ul style="list-style-type: none">• Lock all stall dividers.• Be sure all saddles, tack and equipment, as well as horse(s), are prevented from being thrown about.

^Caution
<p>Hauling a horse in a livestock trailer may result in its serious injury or death.</p> <p>Do not carry a horse in a livestock trailer. Use a trailer designed to carry horses.</p>

2.2.16 **Hazards to Livestock (Livestock Trailer)**

A livestock trailer is designed for the safe transport of livestock, other than horses. It is not equipped for hauling horses.

Before loading your livestock, inspect the interior of the livestock trailer to insure that no hazards are present. Read section 5.7, "Loading Livestock" for specific instructions regarding trailering of livestock other than horses.

^WARNING
<p>Large animals are capable of inflicting serious injury or death to a human handler.</p> <p>Know your animals' temperament before attempting to trailer them.</p>

^Caution
<p>Hauling a horse in a livestock trailer may result in its serious injury or death.</p> <p>Do not carry a horse in a livestock trailer. Use a trailer designed to carry horses.</p>

2.2.17 Hazards from Accessories

The “Accessories” chapter of this manual contains some information about certain optional accessories that may be on your trailer. Read and follow all of these instructions before operating the accessories.

2.2.18 Safety Warning Labels on Your Trailer

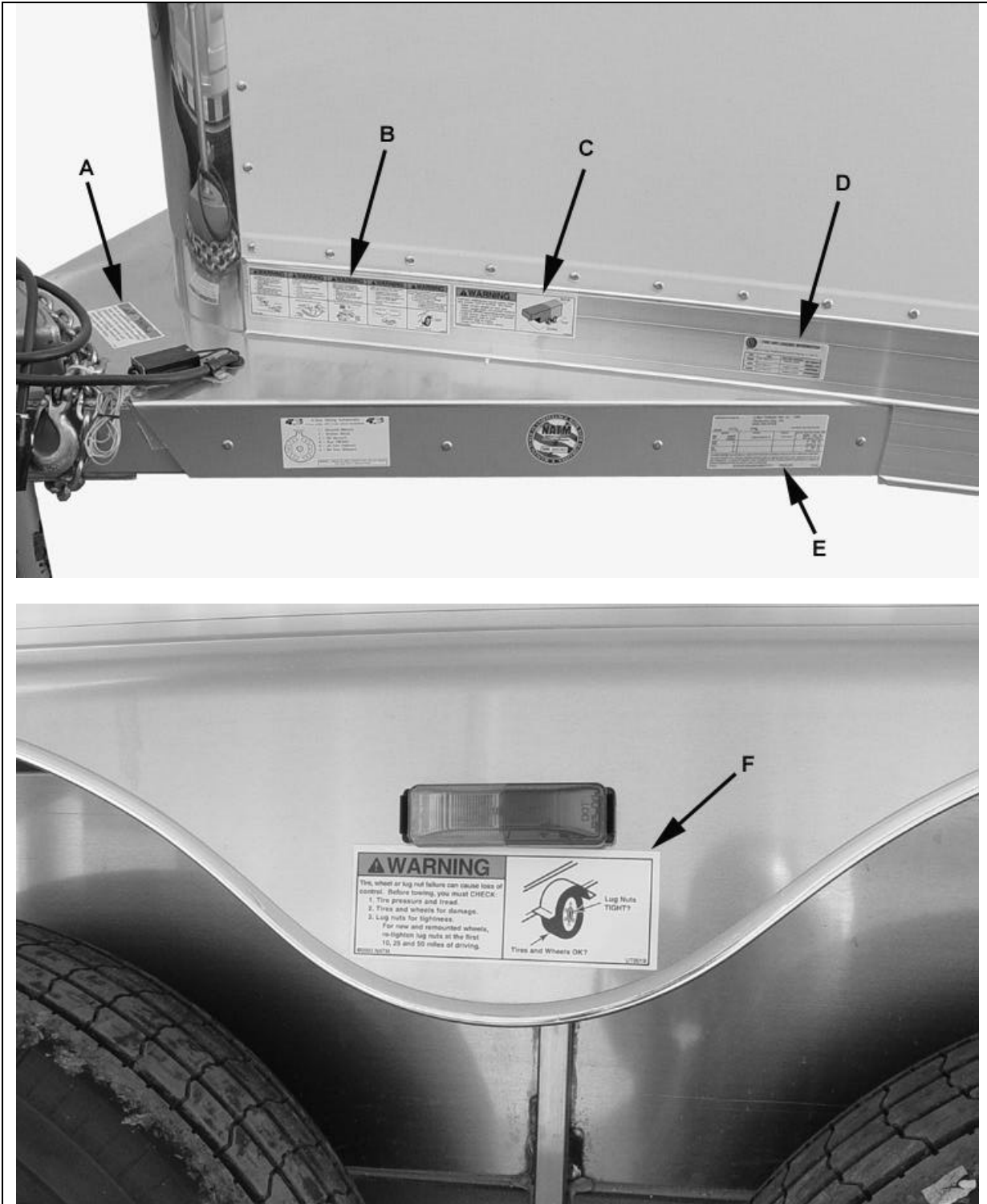

Bumper Pull Trailer Warning Label Locations – Figure 2-1

- A – Part Number 4303029 – Read Owner’s Manual
- B – Part Number 4303030 – Hitch/Safety Chains/Brakes
- C – Part Number 4303027 – Loading Information
- D – Part Number 4303038 – Tire and loading Information
- E – VIN Plate
- F – Part Number 4303028 – Check Tires and Lug Nuts

General Safety Information



Gooseneck Trailer Warning Label Locations – Figure 2-2

- A – VIN Plate**
- B – Part Number 4303026 – Safety Chains/Lights/Brakes**
- C – Part Number 4303027 – Loading Information**
- D – Part Number 4303029 – Read Owner’s Manual**
- E – Part Number 4303028 – Check Tires and Lug Nuts**



Interior Warning Label Location – Figure 2-3

A – Part Number 4303032 – Do Not Sleep In This Area – Warning label located on the interior of the trailer.

^WARNING
<p>To protect you and others against death or serious injury, all of the labels shown above must be on the trailer and must be legible.</p> <p>If any of these labels are missing or cannot be read, call 4-Star Trailers at 405-324-7827 for free replacement labels.</p> <p>You will need to provide us with the number shown at the bottom of the label(s) in order for us to send the correct one(s).</p>

2.2.19 Trailer Towing Guide

Driving a vehicle with a trailer in tow is vastly different from driving the same vehicle without a trailer in tow. Acceleration, maneuverability and braking are all diminished with a trailer in tow. It takes longer to get up to speed; you need more room to turn and pass, and more distance to stop when towing a trailer. You will need to spend time adjusting to the different feel and maneuverability of the tow vehicle with a loaded trailer. Because of the significant differences in all aspects of maneuverability when towing a trailer, the hazards and risks of injury are also much greater than when driving without a trailer. You are responsible for keeping your vehicle and trailer in control, and for all the damage that is caused if you lose control of your vehicle and trailer.

As you did when learning to drive an automobile, find an open area with little or no traffic for your first practice trailering. Of course, before you start towing the trailer, you must follow all of the instructions for inspection, testing, loading and coupling. Also, before you start towing, adjust the mirrors so you can see the trailer as well as the area to the rear of it.

Drive slowly at first, 5 mph or so, and turn the wheel to get the feel of how the tow vehicle and trailer combination responds. Next, make some right and left hand turns. Watch in your side mirrors to see how the trailer follows the tow vehicle. Turning with a trailer attached requires more room.

Stop the rig a few times from speeds no greater than 10 mph. If your trailer is equipped with brakes, try using different combinations of trailer/electric brake and tow

General Safety Information

vehicle brake. Note the effect that the trailer brakes have when they are the only brakes used. When properly adjusted, the trailer brakes will come on just before the tow vehicle brakes.

It will take practice to learn how to back up a tow vehicle with a trailer attached. Take it slow. Before backing up, get out of the tow vehicle and look behind the trailer to make sure that there are no obstacles. Some drivers place their hands at the bottom of the steering wheel, and while the tow vehicle is in reverse,

“think” of the hands as being on the top of the wheel. When the hands move to the right (counter-clockwise, as you would do to turn the tow vehicle to the left when moving forward), the rear of the trailer moves to the right. Conversely, rotating the steering wheel clockwise with your hands at the bottom of the wheel will move the rear of the trailer to the left, while backing up. If you are towing a bumper hitch rig, be careful not to allow the trailer to turn too much, because it will hit the rear of the tow vehicle. To straighten the rig, either pull forward, or turn the steering wheel in the opposite direction.

2.2.20 Reporting Safety Defects

If you believe that your vehicle has a defect that could cause a crash or could cause injury or death, you should immediately inform the National Highway Traffic Safety Administration (NHTSA) in addition to notifying 4-Star Trailers.

If NHTSA receives similar complaints, it may open an investigation, and if it finds that a safety defect exists in a group of vehicles, it may order a recall and remedy campaign. However, NHTSA cannot become involved in individual problems between you, your dealer, or 4-Star Trailers.

To contact NHTSA, you may either call the Vehicle Safety Hotline toll-free at 1-888-327-4236 (TTY: 1-800-424-9153), go to <http://www.safercar.gov>; or write to: Administrator, NHTSA, 400 Seventh Street, SW., Washington, DC 20590. You can also obtain other information about motor vehicle safety from <http://www.safercar.gov>.

Call 405-324-7827 to reach 4-Star Trailers.

2.3 SAFE TRAILER TOWING GUIDELINES

- Recheck the load tiedowns to make sure the load will not shift during towing.
- Before towing, check coupling, safety chain, safety brake, tires, wheels and lights.
- Check the lug nuts or bolts for tightness.
- Check coupler tightness after towing 50 miles.
- Adjust the brake controller to engage the trailer brakes before the tow vehicle brakes. Follow the instructions given with the brake controller manufacturer’s literature.
- Use your mirrors to verify that you have room to change lanes or pull into traffic.

- Use your turn signals well in advance.
- Allow plenty of stopping space for your trailer and tow vehicle.
- Do not drive so fast that the trailer begins to sway due to speed. Generally never drive faster than 60 m.p.h.
- Allow plenty of room for passing. A rule of thumb is that the passing distance with a trailer is 4 times the passing distance without a trailer.
- Shift your automatic transmission into a lower gear for city driving.
- Use lower gears for climbing and descending grades.
- Do not ride the brakes while descending grades, they may get so hot that they stop working. Then you will potentially have a runaway tow vehicle and trailer.
- To conserve fuel, don't use full throttle to climb a hill. Instead, build speed on the approach.
- Slow down for bumps in the road. Take your foot off the brake when crossing the bump.
- Do not brake while in a curve unless absolutely necessary. Instead, slow down before you enter the curve.
- Do not apply the tow vehicle brakes to correct extreme trailer swaying. Instead, lightly apply the trailer brakes with the hand controller.
- Make regular stops, about once each hour. Confirm that
 - The coupler is secure to the hitch and is locked,
 - Electrical connectors are made,
 - There is appropriate slack in the safety chains,
 - There is appropriate slack in the breakaway switch pullpin cable,
 - The tires are not visibly low on pressure, and
 - The cargo is secure and in good condition.

3. TIRE SAFETY INFORMATION

This portion of the Manual contains tire safety information as required by 49 CFR 575.6.

Section 3.1 contains Trailer Tire Information.

Section 3.2 contains "Steps for Determining Correct Load Limit - Trailer".

Section 3.3 contains "Steps for Determining Correct Load Limit – Tow Vehicle".

Section 3.4 contains a Glossary of Tire Terminology, including "cold inflation pressure", "maximum inflation pressure", "recommended inflation pressure", and other non-technical terms.

Section 3.5 contains information from the NHTSA brochure entitled "Tire Safety – Everything Rides On It". This brochure describes the following items;

- Tire labeling, including a description and explanation of each marking on the tires, and information about the DOT Tire Identification Number (TIN).
- Recommended tire inflation pressure, including a description and explanation of:
 - A. Cold inflation pressure.
 - B. Vehicle Placard and location on the vehicle.
 - C. Adverse safety consequences of under inflation (including tire failure).
 - D. Measuring and adjusting air pressure for proper inflation.
- Tire Care, including maintenance and safety practices.
- Vehicle load limits, including a description and explanation of the following items:
 - A. Locating and understanding the load limit information, total load capacity, and cargo capacity.
 - B. Calculating total and cargo capacities with varying seating configurations including quantitative examples showing / illustrating how the vehicles cargo and luggage capacity decreases as combined number and size of occupants' increases. This item is also discussed in Section 3.
 - C. Determining compatibility of tire and vehicle load capabilities.
 - D. Adverse safety consequences of overloading on handling and stopping on tires.

3.1 TRAILER TIRE INFORMATION

Trailer tires may be worn out even though they still have plenty of tread left. This is because trailer tires have to carry a lot of weight all the time, even when not in use. It is actually better for the tire to be rolling down the road than to be idle. During use, the tire releases lubricants that are beneficial to tire life. Using the trailer tires often also helps prevent flat spots from developing.

The main cause of tire failure is improper inflation. Check the cold tire inflation pressures at least once a week for proper inflation levels. "Cold" means that the tires are at the same temperature as the surrounding air, such as when the vehicle has been parked overnight. Wheel and tire manufacturers recommend adjusting the air pressure to the trailer manufacturer's recommended cold inflation pressure, in pounds per square inch (PSI) stated on the vehicle's Federal Certification Label or Tire Placard when the trailer is loaded to its gross vehicle weight rating (GVWR). If the tires are inflated to less than the recommended inflation level or the GVWR of the trailer is exceeded, the load carrying capacity of the tire could be dramatically affected. If the tires are inflated more than the recommended inflation level, handling characteristics of the tow vehicle/trailer combination could be affected. Refer to the owner's manual or talk to your dealer or vehicle manufacturer if you have any questions regarding proper inflation practices.

Tires can lose air over a period of time. In fact, tires can lose 1 to 3 PSI per month. This is because molecules of air, under pressure, weave their way from the inside of the tire, through the rubber, to the outside. A drop in tire pressure could cause the tire to become overloaded, leading to excessive heat build up. If a trailer tire is under-inflated, even for a short period of time, the tire could suffer internal damage.

High speed towing in hot conditions degrades trailer tires significantly. As heat builds up during driving, the tire's internal structure starts to breakdown, compromising the strength of the tire. It is recommended to drive at moderate speeds.

Statistics indicate the average life of a trailer tire is about five years under normal use and maintenance conditions. After three years, replacing the trailer tires with new ones should be considered, even if the tires have adequate tread depth. Some experts claim that after five years, trailer tires are considered worn out and should be replaced, even if they have had minimal or no use. This is such a general statement that it may not

apply in all cases. It is best to have your tires inspected by a tire supplier to determine if your tires need to be replaced.

If you are storing your trailer for an extended period, make sure the tires are fully inflated to the maximum rated pressure and that you store them in a cool, dry place, such as a garage. Use tire covers to protect the trailer tires from the harsh effects of the sun.

3.2 STEPS FOR DETERMINING CORRECT LOAD LIMIT – TRAILER

Determining the load limits of a trailer includes more than understanding the load limits of the tires alone. On all trailers there is a Federal Certification / VIN label that is located on the forward half of the left (road) side of the unit. This certification/VIN label will indicate the trailer's Gross Vehicle Weight Rating (GVWR). This is the most weight the fully loaded trailer can weigh. It will also provide the Gross Axle Weight Rating (GAWR). This is the most a particular axle can weigh. If there are multiple axles, the GAWR of each axle will be provided.

If your trailer has a GVWR of 10,000 pounds or less, there is a vehicle placard located in the same location as the certification label described above. This placard provides tire and loading information. In addition, this placard will show a statement regarding maximum cargo capacity. Cargo can be added to the trailer, up to the maximum weight specified on the placard. The combined weight of the cargo is provided as a single number. In any case, remember: the total weight of a fully loaded trailer can not exceed the stated GVWR.

For trailers with living quarters installed, the weight of water and propane also need to be considered. The weight of fully filled propane containers is considered part of the weight of the trailer before it is loaded with cargo, and is not considered part of the disposable cargo load. Water however, is a disposable cargo weight and is treated as such. If there is a fresh water storage tank of 100 gallons, this tank when filled would weigh about 800 pounds. If more cargo is being transported, water can be off-loaded to keep the total amount of cargo added to the vehicle within the limits of the GVWR so as not to overload the vehicle. Understanding this flexibility will allow you, the owner, to make choices that fit your travel needs.

When loading your cargo, be sure it is distributed evenly to prevent overloading front to back and side to side. Heavy items should be placed low and as close to the axle positions as reasonable. Too many items on one side may overload a tire. The best way to know the actual weight of the vehicle is to weigh it at a public scale. Talk to your dealer to discuss the weighing

methods needed to capture the various weights related to the trailer. This would include the weight empty or unloaded, weights per axle, wheel, hitch or king-pin, and total weight.

Excessive loads and/or under inflation cause tire overloading and, as a result, abnormal tire flexing occurs. This situation can generate an excessive amount of heat within the tire. Excessive heat may lead to tire failure. It is the air pressure that enables a tire to support the load, so proper inflation is critical. The proper air pressure may be found on the Certification / VIN label and/or on the Tire Placard. This value should never exceed the maximum cold inflation pressure stamped on the tire.

3.2.1 Trailers 10,000 Pounds GVWR or Less

1. Locate the statement, "The weight of cargo should never exceed XXX kg or XXX lbs." on your vehicle's placard. This placard is attached adjacent to or near the trailer's VIN (Certification) label at the left front of the trailer. See figure 3-1.
2. This figure equals the available amount of cargo and luggage load capacity.
3. Determine the combined weight of luggage and cargo being loaded on the vehicle. That weight may not safely exceed the available cargo and luggage load capacity.

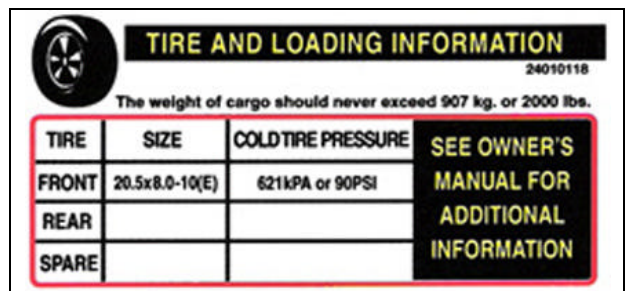

Tire and Loading Information – Figure 3-1

3.2.2 Trailers Over 10,000 Pounds GVWR

Note: These trailers are not required to have a Tire and Loading Information placard on the vehicle.

1. Determine the empty weight of your trailer by weighing the trailer using a public scale or other means. This step does not have to be repeated.
2. Locate the GVWR (Gross Vehicle Weight Rating) of the trailer on your trailer's VIN (Certification) label.
3. Subtract the empty weight of your trailer from the GVWR stated on the VIN label. That weight is the maximum available cargo capacity of the trailer and may not be safely exceeded.

3.3 STEPS FOR DETERMINING CORRECT LOAD LIMIT – TOW VEHICLE

1. Locate the statement, "The combined weight of occupants and cargo should never exceed XXX lbs.," on your vehicle's placard.
2. Determine the combined weight of the driver and passengers who will be riding in your vehicle.
3. Subtract the combined weight of the driver and passengers from XXX kilograms or XXX pounds.
4. The resulting figure equals the available amount of cargo and luggage capacity. For example, if the "XXX" amount equals 1400 lbs. and there will be five 150 lb. passengers in your vehicle, the amount of available cargo and luggage capacity is 650 lbs. (1400-750 (5 x 150) = 650 lbs.).
5. Determine the combined weight of luggage and cargo being loaded on the vehicle. That weight may not safely exceed the available cargo and luggage capacity calculated in Step # 4.
6. If your vehicle will be towing a trailer, load from your trailer will be transferred to your vehicle. Consult the tow vehicle's manual to determine how this weight transfer reduces the available cargo and luggage capacity of your vehicle.

3.4 GLOSSARY OF TIRE TERMINOLOGY

Accessory weight

The combined weight (in excess of those standard items which may be replaced) of automatic transmission, power steering, power brakes, power windows, power seats, radio and heater, to the extent that these items are available as factory-installed equipment (whether installed or not).

Bead

The part of the tire that is made of steel wires, wrapped or reinforced by ply cords and that is shaped to fit the rim.

Bead separation

This is the breakdown of the bond between components in the bead.

Bias ply tire

A pneumatic tire in which the ply cords that extend to the beads are laid at alternate angles substantially less than 90 degrees to the centerline of the tread.

Carcass

The tire structure, except tread and sidewall rubber which, when inflated, bears the load.

Chunking

The breaking away of pieces of the tread or sidewall.

Cold inflation pressure

The pressure in the tire before you drive.

Cord

The strands forming the plies in the tire.

Cord separation

The parting of cords from adjacent rubber compounds.

Cracking

Any parting within the tread, sidewall, or inner liner of the tire extending to cord material.

CT

A pneumatic tire with an inverted flange tire and rim system in which the rim is designed with rim flanges pointed radially inward and the tire is designed to fit on the underside of the rim in a manner that encloses the rim flanges inside the air cavity of the tire.

Curb weight

The weight of a motor vehicle with standard equipment including the maximum capacity of fuel, oil, and coolant, and, if so equipped, air conditioning and additional weight optional engine.

Extra load tire

A tire designed to operate at higher loads and at higher inflation pressures than the corresponding standard tire.

Groove

The space between two adjacent tread ribs.

Innerliner

The layer(s) forming the inside surface of a tubeless tire that contains the inflating medium within the tire.

Innerliner separation

The parting of the innerliner from cord material in the carcass.

Intended outboard sidewall

The sidewall that contains a white-wall, bears white lettering or bears manufacturer, brand, and/or model name molding that is higher or deeper than the same molding on the other sidewall of the tire or the outward facing sidewall of an asymmetrical tire that has a particular side that must always face outward when mounted on a vehicle.

Light truck (LT) tire

A tire designated by its manufacturer as primarily intended for use on lightweight trucks or multipurpose passenger vehicles.

Load rating

Tire Safety Information

The maximum load that a tire is rated to carry for a given inflation pressure.

Maximum load rating

The load rating for a tire at the maximum permissible inflation pressure for that tire.

Maximum permissible inflation pressure

The maximum cold inflation pressure to which a tire may be inflated.

Maximum loaded vehicle weight

The sum of curb weight, accessory weight, vehicle capacity weight, and production options weight.

Measuring rim

The rim on which a tire is fitted for physical dimension requirements.

Non-pneumatic rim

A mechanical device which, when a non-pneumatic tire assembly incorporates a wheel, supports the tire, and attaches, either integrally or separably, to the wheel center member and upon which the tire is attached.

Non-pneumatic spare tire assembly

A non-pneumatic tire assembly intended for temporary use in place of one of the pneumatic tires and rims that are fitted to a passenger car in compliance with the requirements of this standard.

Non-pneumatic tire

A mechanical device which transmits, either directly or through a wheel or wheel center member, the vertical load and tractive forces from the roadway to the vehicle, generates the tractive forces that provide the directional control of the vehicle and does not rely on the containment of any gas or fluid for providing those functions.

Non-pneumatic tire assembly

A non-pneumatic tire, alone or in combination with a wheel or wheel center member, which can be mounted on a vehicle.

Normal occupant weight

This means 68 kilograms (150 lbs.) times the number of occupants specified in the second column of Table I of 49 CFR 571.110.

Occupant distribution

The distribution of occupants in a vehicle as specified in the third column of Table I of 49 CFR 571.110.

Open splice

Any parting at any junction of tread, sidewall, or innerliner that extends to cord material.

Outer diameter

The overall diameter of an inflated new tire.

Overall width

The linear distance between the exteriors of the sidewalls of an inflated tire, including elevations due to labeling, decorations, or protective bands or ribs.

Ply

A layer of rubber-coated parallel cords.

Ply separation

A parting of rubber compound between adjacent plies.

Pneumatic tire

A mechanical device made of rubber, chemicals, fabric and steel or other materials, that, when mounted on an automotive wheel, provides the traction and contains the gas or fluid that sustains the load.

Production options weight

The combined weight of those installed regular production options weighing over 2.3 kilograms (5 lbs.) in excess of those standard items which they replace, not previously considered in curb weight or accessory weight, including heavy duty brakes, ride levelers, roof rack, heavy duty battery, and special trim.

Radial ply tire

A pneumatic tire in which the ply cords that extend to the beads are laid at substantially 90 degrees to the centerline of the tread.

Recommended inflation pressure

This is the inflation pressure provided by the vehicle manufacturer on the Tire Information label and on the Certification / VIN tag.

Reinforced tire

A tire designed to operate at higher loads and at higher inflation pressures than the corresponding standard tire.

Rim

A metal support for a tire or a tire and tube assembly upon which the tire beads are seated.

Rim diameter

This means the nominal diameter of the bead seat.

Rim size designation

This means the rim diameter and width.

Rim type designation

This means the industry of manufacturer's designation for a rim by style or code.

Rim width

This means the nominal distance between rim flanges.

Section width

The linear distance between the exteriors of the sidewalls of an inflated tire, excluding elevations due to labeling, decoration, or protective bands.

Sidewall

That portion of a tire between the tread and bead.

Sidewall separation

The parting of the rubber compound from the cord material in the sidewall.

Special Trailer (ST) tire

The "ST" is an indication the tire is for trailer use only.

Test rim

The rim on which a tire is fitted for testing, and may be any rim listed as appropriate for use with that tire.

Tread

That portion of a tire that comes into contact with the road.

Tread rib

A tread section running circumferentially around a tire.

Tread separation

Pulling away of the tread from the tire carcass.

Treadwear indicators (TWI)

The projections within the principal grooves designed to give a visual indication of the degrees of wear of the tread.

Vehicle capacity weight

The rated cargo and luggage load plus 68 kilograms (150 lbs.) times the vehicle's designated seating capacity.

Vehicle maximum load on the tire

The load on an individual tire that is determined by distributing to each axle its share of the maximum loaded vehicle weight and dividing by two.

Vehicle normal load on the tire

The load on an individual tire that is determined by distributing to each axle its share of the curb weight, accessory weight, and normal occupant weight (distributed in accordance with Table I of CRF 49 571.110) and dividing by 2.

Weather side

The surface area of the rim not covered by the inflated tire.

Wheel center member

In the case of a non-pneumatic tire assembly incorporating a wheel, a mechanical device which attaches, either integrally or separably, to the non-pneumatic rim and provides the connection between the non-pneumatic rim and the vehicle; or, in the case of a non-pneumatic tire assembly not incorporating a wheel, a mechanical device which attaches, either integrally or separably, to the non-pneumatic tire and provides the connection between tire and the vehicle.

Wheel-holding fixture

The fixture used to hold the wheel and tire assembly securely during testing.

3.5 TIRE SAFETY - EVERYTHING RIDES ON IT

The National Traffic Safety Administration (NHTSA) has published a brochure (DOT HS 809 361) that discusses all aspects of Tire Safety, as required by CFR 575.6. This brochure is reproduced in part below. It can be obtained and downloaded from NHTSA, free of charge, from the following web site:

http://www.nhtsa.dot.gov/cars/rules/TireSafety/ridesonit/tires_index.html

Studies of tire safety show that maintaining proper tire pressure, observing tire and vehicle load limits (not carrying more weight in your vehicle than your tires or vehicle can safely handle), avoiding road hazards, and inspecting tires for cuts, slashes, and other irregularities are the most important things you can do to avoid tire failure, such as tread separation or blowout and flat tires. These actions, along with other care and maintenance activities, can also:

- Improve vehicle handling
- Help protect you and others from avoidable breakdowns and accidents
- Improve fuel economy
- Increase the life of your tires.

This booklet presents a comprehensive overview of tire safety, including information on the following topics:

- Basic tire maintenance
- Uniform Tire Quality Grading System
- Fundamental characteristics of tires
- Tire safety tips.

Use this information to make tire safety a regular part of your vehicle maintenance routine. Recognize that the time you spend is minimal compared with the

inconvenience and safety consequences of a flat tire or other tire failure.

3.5.1 Safety First—Basic Tire Maintenance

Properly maintained tires improve the steering, stopping, traction, and load-carrying capability of your vehicle. Underinflated tires and overloaded vehicles are a major cause of tire failure. Therefore, as mentioned above, to avoid flat tires and other types of tire failure, you should maintain proper tire pressure, observe tire and vehicle load limits, avoid road hazards, and regularly inspect your tires.

3.5.2 Finding Your Vehicle's Recommended Tire Pressure and Load Limits

Tire information placards and vehicle certification labels contain information on tires and load limits. These labels indicate the vehicle manufacturer's information including:

- Recommended tire size.
- Recommended tire inflation pressure
- Vehicle capacity weight (VCW—the maximum occupant and cargo weight a vehicle is designed to carry).
- Front and rear gross axle weight ratings (GAWR—the maximum weight the axle systems are designed to carry).

Both placards and certification labels are permanently attached to the trailer near the left front.

3.5.3 Understanding Tire Pressure and Load Limits

Tire inflation pressure is the level of air in the tire that provides it with load-carrying capacity and affects the overall performance of the vehicle. The tire inflation pressure is a number that indicates the amount of air pressure—measured in pounds per square inch (psi)—a tire requires to be properly inflated. (You will also find this number on the vehicle information placard expressed in kilopascals (kPa), which is the metric measure used internationally.)

Manufacturers of passenger vehicles and light trucks determine this number based on the vehicle's design load limit, that is, the greatest amount of weight a vehicle can safely carry and the vehicle's tire size. The proper tire pressure for your vehicle is referred to as the "recommended cold inflation pressure." (As you will read below, it is difficult to obtain the recommended tire pressure if your tires are not cold.)

Because tires are designed to be used on more than one type of vehicle, tire manufacturers list the "maximum permissible inflation pressure" on the tire

sidewall. This number is the greatest amount of air pressure that should ever be put in the tire under normal driving conditions.

3.5.4 Checking Tire Pressure

It is important to check your vehicle's tire pressure at least once a month for the following reasons:

- Most tires may naturally lose air over time.
- Tires can lose air suddenly if you drive over a pothole or other object or if you strike the curb when parking.
- With radial tires, it is usually not possible to determine underinflation by visual inspection.

For convenience, purchase a tire pressure gauge to keep in your vehicle. Gauges can be purchased at tire dealerships, auto supply stores, and other retail outlets. The recommended tire inflation pressure that vehicle manufacturers provide reflects the proper psi when a tire is cold. The term cold does not relate to the outside temperature. Rather, a cold tire is one that has not been driven on for at least three hours. When you drive, your tires get warmer, causing the air pressure within them to increase. Therefore, to get an accurate tire pressure reading, you must measure tire pressure when the tires are cold or compensate for the extra pressure in warm tires.

3.5.5 Steps for Maintaining Proper Tire Pressure

Step 1: Locate the recommended tire pressure on the vehicle's tire information placard, certification label, or in the owner's manual.

Step 2: Record the tire pressure of all tires.

Step 3: If the tire pressure is too high in any of the tires, slowly release air by gently pressing on the tire valve stem with the edge of your tire gauge until you get to the correct pressure.

Step 4: If the tire pressure is too low, note the difference between the measured tire pressure and the correct tire pressure. These "missing" pounds of pressure are what you will need to add.

Step 5: At a service station, add the missing pounds of air pressure to each tire that is underinflated.

Step 6: Check all the tires to make sure they have the same air pressure (except in cases in which the front and rear tires are supposed to have different amounts of pressure).

If you have been driving your vehicle and think that a tire is underinflated, fill it to the recommended cold inflation pressure indicated on your vehicle's tire information

placard or certification label. While your tire may still be slightly underinflated due to the extra pounds of pressure in the warm tire, it is safer to drive with air pressure that is slightly lower than the vehicle manufacturer's recommended cold inflation pressure than to drive with a significantly underinflated tire. Since this is a temporary fix, don't forget to recheck and adjust the tire's pressure when you can obtain a cold reading.

3.5.6 Tire Size

To maintain tire safety, purchase new tires that are the same size as the vehicle's original tires or another size recommended by the manufacturer. Look at the tire information placard, the owner's manual, or the sidewall of the tire you are replacing to find this information. If you have any doubt about the correct size to choose, consult with the tire dealer.

3.5.7 Tire Tread

The tire tread provides the gripping action and traction that prevent your vehicle from slipping or sliding, especially when the road is wet or icy. In general, tires are not safe and should be replaced when the tread is worn down to 1/16 of an inch. Tires have built-in treadwear indicators that let you know when it is time to replace your tires. These indicators are raised sections spaced intermittently in the bottom of the tread grooves. When they appear "even" with the outside of the tread, it is time to replace your tires. Another method for checking tread depth is to place a penny in the tread with Lincoln's head upside down and facing you. If you can see the top of Lincoln's head, you are ready for new tires.

3.5.8 Tire Balance and Wheel Alignment

To avoid vibration or shaking of the vehicle when a tire rotates, the tire must be properly balanced. This balance is achieved by positioning weights on the wheel to counterbalance heavy spots on the wheel-and-tire assembly. A wheel alignment adjusts the angles of the wheels so that they are positioned correctly relative to the vehicle's frame. This adjustment maximizes the life of your tires. These adjustments require special equipment and should be performed by a qualified technician.

3.5.9 Tire Repair

The proper repair of a punctured tire requires a plug for the hole and a patch for the area inside the tire that surrounds the puncture hole. Punctures through the tread can be repaired if they are not too large, but punctures to the sidewall should not be repaired. Tires must be removed from the rim to be properly inspected before being plugged and patched.

3.5.10 Tire Fundamentals

Federal law requires tire manufacturers to place standardized information on the sidewall of all tires. This information identifies and describes the fundamental characteristics of the tire and also provides a tire identification number for safety standard certification and in case of a recall.

3.5.10.1. Information on Passenger Vehicle Tires

Please refer to the diagram below.

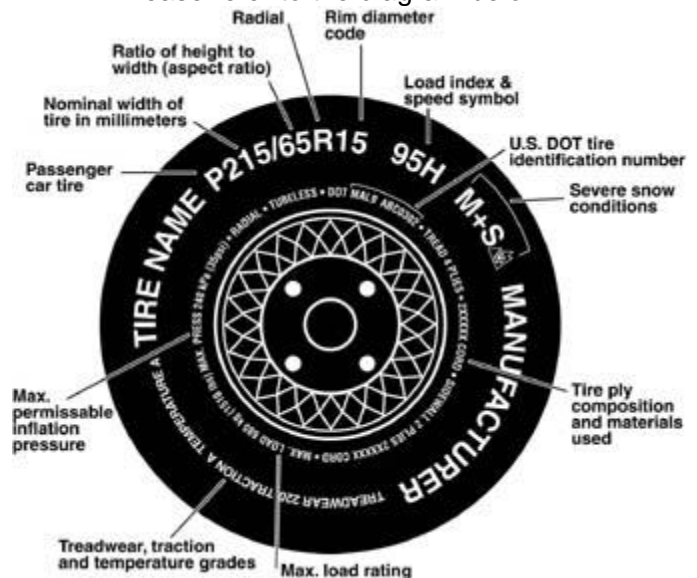

P

The "P" indicates the tire is for passenger vehicles.

Next number

This three-digit number gives the width in millimeters of the tire from sidewall edge to sidewall edge. In general, the larger the number, the wider the tire.

Next number

This two-digit number, known as the aspect ratio, gives the tire's ratio of height to width. Numbers of 70 or lower indicate a short sidewall for improved steering response and better overall handling on dry pavement.

R

The "R" stands for radial. Radial ply construction of tires has been the industry standard for the past 20 years.

Next number

This two-digit number is the wheel or rim diameter in inches. If you change your wheel size, you will have to purchase new tires to match the new wheel diameter.

Next number

This two- or three-digit number is the tire's load index. It is a measurement of how much weight each tire can support. You may find this information in your owner's

Tire Safety Information

manual. If not, contact a local tire dealer. Note: You may not find this information on all tires because it is not required by law.

M+S

The "M+S" or "M/S" indicates that the tire has some mud and snow capability. Most radial tires have these markings; hence, they have some mud and snow capability.

Speed Rating

The speed rating denotes the speed at which a tire is designed to be driven for extended periods of time. The ratings range from 99 miles per hour (mph) to 186 mph. These ratings are listed below. Note: You may not find this information on all tires because it is not required by law.

Letter Rating	Speed Rating
Q	99 mph
R	106 mph
S	112 mph
T	118 mph
U	124 mph
H	130 mph
V	149 mph
W	168* mph
Y	186* mph

* For tires with a maximum speed capability over 149 mph, tire manufacturers sometimes use the letters ZR. For those with a maximum speed capability over 186 mph, tire manufacturers always use the letters ZR.

U.S. DOT Tire Identification Number

This begins with the letters "DOT" and indicates that the tire meets all federal standards. The next two numbers or letters are the plant code where it was manufactured, and the last four numbers represent the week and year the tire was built. For example, the numbers 3197 means the 31st week of 1997. The other numbers are marketing codes used at the manufacturer's discretion. This information is used to contact consumers if a tire defect requires a recall.

Tire Ply Composition and Materials Used

The number of plies indicates the number of layers of rubber-coated fabric in the tire. In general, the greater the number of plies, the more weight a tire can support. Tire manufacturers also must indicate the materials in the tire, which include steel, nylon, polyester, and others.

Maximum Load Rating

This number indicates the maximum load in kilograms and pounds that can be carried by the tire.

Maximum Permissible Inflation Pressure

This number is the greatest amount of air pressure that should ever be put in the tire under normal driving conditions.

3.5.10.2. UTQGS Information

Treadwear Number

This number indicates the tire's wear rate. The higher the treadwear number is, the longer it should take for the tread to wear down. For example, a tire graded 400 should last twice as long as a tire graded 200.

Traction Letter

This letter indicates a tire's ability to stop on wet pavement. A higher graded tire should allow you to stop your car on wet roads in a shorter distance than a tire with a lower grade. Traction is graded from highest to lowest as "AA", "A", "B", and "C".

Temperature Letter

This letter indicates a tire's resistance to heat. The temperature grade is for a tire that is inflated properly and not overloaded. Excessive speed, underinflation or excessive loading, either separately or in combination, can cause heat build-up and possible tire failure. From highest to lowest, a tire's resistance to heat is graded as "A", "B", or "C".

3.5.10.3. Additional Information on Light Truck Tires

Please refer to the following diagram.

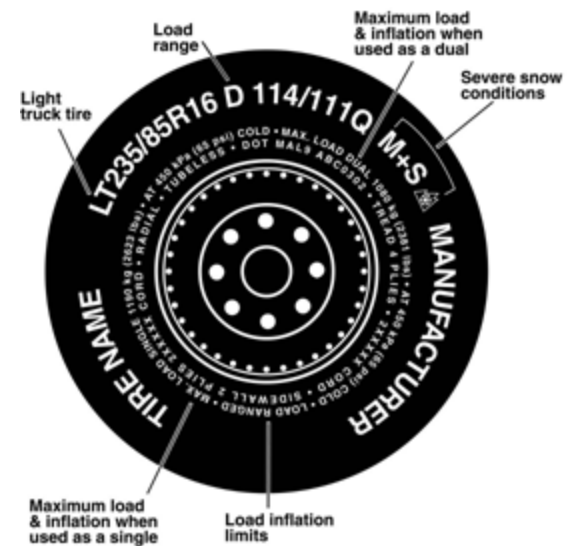

Tires for light trucks have other markings besides those found on the sidewalls of passenger tires.

LT

The "LT" indicates the tire is for light trucks or trailers.

ST

An "ST" is an indication the tire is for trailer use only.

Max. Load Dual kg (lbs) at kPa (psi) Cold

This information indicates the maximum load and tire pressure when the tire is used as a dual, that is, when four tires are put on each rear axle (a total of six or more tires on the vehicle).

Max. Load Single kg (lbs) at kPa (psi) Cold

This information indicates the maximum load and tire pressure when the tire is used as a single.

Load Range

This information identifies the tire's load-carrying capabilities and its inflation limits.

3.5.11 Tire Safety Tips

Preventing Tire Damage

- Slow down if you have to go over a pothole or other object in the road.
- Do not run over curbs or other foreign objects in the roadway, and try not to strike the curb when parking.

Tire Safety Checklist

- Check tire pressure regularly (at least once a month), including the spare.
- Inspect tires for uneven wear patterns on the tread, cracks, foreign objects, or other signs of wear or trauma.
- Remove bits of glass and foreign objects wedged in the tread.
- Make sure your tire valves have valve caps.
- Check tire pressure before going on a long trip.
- Do not overload your vehicle. Check the Tire Information and Loading Placard or User's Manual for the maximum recommended load for the vehicle.

4. COUPLING TO THE TOW VEHICLE

Follow all of the safety precautions and instructions in this manual to ensure safety of persons, cargo, and satisfactory life of the trailer.

4.1 USE AN ADEQUATE TOW VEHICLE AND HITCH

If the vehicle or hitch is not properly selected and matched to the Gross Vehicle Weight Rating (GVWR) of your trailer, you can cause an accident that could lead to death or serious injury. If you already have a tow vehicle, know your vehicle tow rating, and Gross Combination Weight Rating (GCWR) and make certain the trailer's rated capacity is less than or equal to the tow vehicle's rated towing capacity. If you already have (or plan to buy) a trailer, make certain that the tow rating of the tow vehicle is equal to or greater than the GVWR of the trailer, and that the GCWR will be within limits.

^Danger

Use of a hitch with a load rating less than the load rating of the trailer can result in loss of control and may lead to death or serious injury.

Use of a tow vehicle with a towing capacity less than the load rating of the trailer can result in loss of control, and may lead to death or serious injury.

Be sure your hitch and tow vehicle are rated for the Gross Vehicle Weight Rating (GVWR) of your trailer.

4.1.1 Trailer Information

Certification / VIN Label

The location of the "Certification / VIN Tag" is shown in figure 4-1 and 4-2.



Bumper Pull trailer Certification / VIN Tag – Figure 4-1



Gooseneck Trailer Certification / VIN Tag – Figure 4-2

The trailer Certification / VIN tag contains the following critical safety information for the use of your trailer:

- **MANUFACTURER:** 4-Star Trailers
- **DATE OF MANUFACTURE:** Month and year the trailer was manufactured.
- **GVWR:** The Gross Vehicle Weight Rating is the maximum allowable gross weight of the trailer and its contents. The gross weight of the trailer includes the weight of the trailer and all of the items within it (such as cargo, water, food and other supplies).
- **GAWR:** The Gross Axle Weight Rating is the maximum gross weight that an axle can support. It is the lowest of axle, wheel, or tire rating. Sometimes the tire or wheel rating is lower than the axle manufacturers rating, and will then determine GAWR.

The sum total of the GAWR for all trailer axles may be less than the GVWR for the trailer, because

some of the trailer load is carried by the tow vehicle, rather than by the trailer axle(s). The total weight of the cargo and trailer must not exceed the GVWR, and the load on an axle must not exceed its GAWR.

- **TIRE SIZE:** The tire size recommended for your trailer and load range.
- **PSIC:** The “pounds per square inch- cold” is the tire pressure (Kilopascals / Pounds per Square Inch) measured when Cold.
- **CERTIFICATION STATEMENT:** “This trailer meets all the Federal Motor Vehicle Safety Standards in effect on the date of manufacture shown above”.
- **VIN:** The Vehicle Identification Number.
- **VEHICLE TYPE:** Trailer

4.1.2 Tow Vehicle

When equipping a new vehicle or an older vehicle to tow your trailer, ask the vehicle dealer for advice on how to outfit the towing vehicle. Discuss the following information and equipment with the vehicle dealer.

- **Overall Carrying and Towing Capacity of Vehicle:** Vehicle manufacturers will provide you with the maximum towing capacities of their various models, as well as the GCWR. No amount of reinforcement will give a 100 horsepower, 2,500 pound truck the towing capacity that a 300 horsepower, 5,000 pound truck has.
- **Towing Hitch:** The towing hitch attached to your tow vehicle must have a capacity equal to or greater than the load rating of the trailer you intend to tow. The hitch capacity must also be matched to the tow vehicle capacity.
- **Suspension System:** A tow vehicle equipped with a factory installed “Towing Package” likely comes equipped with heavy duty springs, heavy duty tires and other suspension components which are able to serve the size and weight of the trailer that the vehicle is rated to tow. However, the addition of additional equipment may further improve the tow vehicle performance. These may include adjustable air shocks, helper springs, etc.
- **Brake Controller:** The brake controller is part of the tow vehicle and is essential in the operation of the electric brakes on the trailer. If your trailer has

electric brakes it requires a brake controller be installed at the driver’s position. The brake controller is not the same as the safety breakaway brake system that is installed on the trailer.

- **Side View Mirrors:** The size of the trailer that is being towed and your state law regulations determine the size of the mirrors. However, some states prohibit extended mirrors on a tow vehicle, except while a trailer is actually being towed. In this situation, detachable extended mirrors are necessary. Check with your dealer or the appropriate state agency for mirror requirements.
- **Heavy Duty Flasher:** A Heavy Duty Flasher is an electrical component that may be required when your trailer turn signal lights are attached to the tow vehicle flasher circuit.
- **Electrical Connector:** An Electrical Connector connects the light and brake systems on the trailer to the light and brake controls on the towing vehicle.
- **Heavy Duty Engine Oil Cooling System:** The tow vehicle engine works harder when a trailer is being towed. Depending on the size of the trailer, you may need to install a separate engine oil cooler. Inadequate cooling may result in sudden engine failure. Ask the tow vehicle dealer if it is necessary to install a heavy duty cooling system.
- **Automatic Transmission Oil Cooler:** The automatic transmission of a towing vehicle handles more power when a trailer is being towed. Inadequate cooling will shorten transmission life, and may result in sudden transmission failure. Ask the tow vehicle dealer if it is necessary to install a separate oil cooler for the automatic transmission.
- **Fire Extinguisher:** It is sensible to have a fire extinguisher in the tow vehicle.
- **Emergency Flares and Emergency Triangle Reflectors:** It is wise to carry these warning devices even if you are not towing a trailer. It is particularly important to have these when towing a trailer because the hazard flashers of your towing vehicle will not operate for as long a period of time when the battery is running both the trailer lights and tow vehicle lights.

4.2 COUPLING AND UNCOUPLING THE TRAILER

A secure coupling (or fastening) of the trailer to the tow vehicle is essential. A loss of coupling may result in death or serious injury. Therefore, you must understand and follow all of the instructions for coupling.

The following parts are involved in making a secure coupling between the trailer and tow vehicle:

Coupler: That part of the trailer connecting mechanism by which the connection is actually made to the trailer hitch. This does not include any structural member, extension of the trailer frame, or brake controller.

Hitch: That part of the connecting mechanism including the ball support platform and ball and those components that extend and are attached to the towing vehicle, including bumpers intended to serve as hitches.)

Safety chains: Chains permanently attached to the trailer such that if the coupler connection comes loose, the safety chains or cables can keep the trailer attached to the tow vehicle. With properly rigged safety chains, it is possible to keep the tongue of the trailer from digging into the road pavement, even if the coupler-to-hitch connection comes apart.

Trailer Lighting and Brake Connector: A device that connects electrical power from the tow vehicle to the trailer. In addition, if your trailer has a separate braking system, the electrical connector will also supply power to the trailer brakes from the tow vehicle.

Breakaway switch: If the trailer becomes de-coupled from the towing vehicle, the breakaway switch lanyard, attached independently to the tow vehicle hitch, will pull a pin in the emergency electrical breakaway switch on the trailer. The breakaway switch is activated by a separate battery supply on the trailer such as to energize the trailer brakes independently of the towing vehicle. It is important to check the state of charge of the emergency breakaway battery before each trip.

Jack: A device on the trailer that is used to raise and lower the trailer tongue.

^WARNING

An improperly coupled trailer can result in death or serious injury.

Do not move the trailer until:

- **The coupler is secured and locked to hitch;**
- **The safety chains are secured to the tow vehicle; and**
- **The trailer jack(s) are fully retracted.**

Do not tow the trailer on the road until:

- **Tires and wheels are checked;**
- **The trailer brakes are checked;**
- **The breakaway switch is connected to the tow vehicle;**
- **The load is secured to the trailer; and**
- **The trailer lights are connected and checked.**

4.2.1 Various Coupler Designs

Trailers are produced with a variety of coupler devices. One of the following sections will pertain to your trailer.

Bumper Pull Ball Coupler
Gooseneck With Ball Coupler or King Pin

If the coupler on your trailer does not resemble one of the couplers shown in the figures, see the separate coupler instructions. If you do not have separate coupler instructions, call 4-Star Trailers at 405-324-7827 for assistance.

4.3 BUMPER PULL TRAILERS

A ball hitch coupler connects to a ball that is located on or under the rear bumper of tow vehicle. This system of coupling a trailer to a tow vehicle is sometimes referred to as "bumper pull." See figure 4-3.

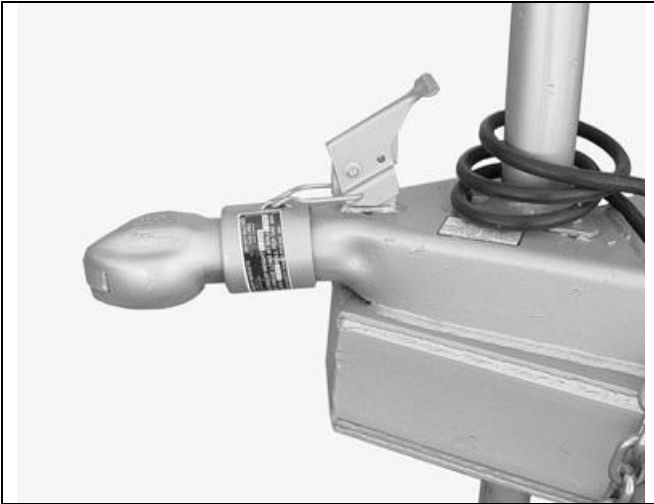

Bumper Pull Trailer With Ball Coupler – Figure 4-3

We have utilized a coupler that is suitable for the size and weight of the trailer. The load rating of the coupler and the necessary ball size are listed on the trailer tongue. You must provide a hitch and ball for your tow vehicle, where the load rating of the hitch and ball is equal to or greater than that of your trailer. Also, the ball size must be the same as the coupler size. If the hitch ball is too small, too large, is underrated, is loose or is worn, the trailer can come loose from the tow vehicle, and may cause death or serious injury.

THE TOW VEHICLE, HITCH AND BALL MUST HAVE A RATED TOWING CAPACITY EQUAL TO OR GREATER THAN THE TRAILER GROSS VEHICLE WEIGHT RATING (GVWR).

IT IS ESSENTIAL THAT THE HITCH BALL BE OF THE SAME SIZE AS THE COUPLER.

The ball size and load rating (capacity) are marked on the ball; hitch capacity is marked on the hitch.

4.3.1 Before Coupling The Trailer To The Tow Vehicle

- Be sure the size and rating of hitch ball match the size and rating of the coupler. Hitch balls and couplers are marked with their size and rating.

^WARNING

Coupler-to-hitch mismatch can result in uncoupling, leading to death or serious injury.

Be sure the LOAD RATING of the hitch ball is equal or greater than the load rating of the coupler.

Be sure the SIZE of the hitch ball matches the size of the coupler.

- Wipe the hitch ball clean and inspect it visually and by feel for flat spots, cracks and pits.

^WARNING

A worn, cracked or corroded hitch ball can fail while towing, and may result in death or serious injury.

Before coupling trailer, inspect the hitch ball for wear, corrosion and cracks.

Replace worn or damaged hitch ball.

- Rock the ball to make sure it is tight to the hitch, and visually check that the hitch ball nut is solid against the lock washer and hitch frame.
- Wipe the inside and outside of the coupler clean and inspect it visually for cracks and deformations; feel the inside of the coupler for worn spots and pits.
- Be sure the coupler is tight to the tongue of the trailer. All coupler fasteners must be visibly solid against the trailer frame.

^WARNING

A loose hitchball nut can result in uncoupling, leading to death or serious injury.

Be sure the hitch ball is tight to the hitch before coupling the trailer.

Raise the bottom surface of the coupler to be above the top of the hitch ball using the jack.

4.3.2 Prepare The Coupler And Hitch Ball

- Lubricate the hitch ball and the inside of the coupler with a thin layer of automotive bearing grease.

- Open the coupler locking mechanism. Ball couplers have a locking mechanism with an internal moving piece (ball clamp) and an outside handle, wheel, or latch.
- In the open position, the coupler is able to drop fully onto the hitch ball. See the coupler instructions for details of placing the coupler in the “open” position.
- Slowly back up the tow vehicle so that the hitch ball is near or aligned under the coupler.

4.3.3 Couple The Trailer To The Tow Vehicle

- Using the jack, lower the trailer tongue until the coupler fully engages the hitch ball. If the coupler does not line up with the hitch ball, adjust the position of the tow vehicle.
- Engage the coupler locking mechanism. In the engaged position, the locking mechanism securely holds the coupler to the hitch ball.
- Insert the lock pin through the hole in the locking mechanism and engage the safety latch.
- Be sure the coupler is all the way on the hitch ball and the locking mechanism is engaged. A properly engaged locking mechanism will allow the coupler to raise the rear of the tow vehicle. Using the trailer jack, test to see that you can raise the rear of the tow vehicle by 1 inch, after the coupler is locked to the hitch.

Error! Not a valid filename.

If the coupler cannot be secured to the hitch ball, do not tow the trailer. Call 4-Star Trailers at 405-324-7827 or your dealer for assistance.

- Lower the trailer so that its entire tongue weight is held by the hitch, and continue retracting the jack to its fully retracted position.

4.3.4 Rig The Safety Chains

- Visually inspect the safety chains and hooks for wear or damage. Replace worn or damaged safety chains and hooks before towing.
- Rig the safety chains so that they:
- Cris-cross underneath the coupler so if the trailer uncouples, the safety chains can hold the tongue up above the road. See figure 4-4.
- Loop around a frame member of the tow vehicle or to holes provided in the hitch system (but, do **not** attach them to an interchangeable part of the hitch assembly)
- Attach “S” hooks up from underneath the hole (do not just drop into hole); and
- Provide enough slack to permit tight turns, but not be close to the road surface to drag.

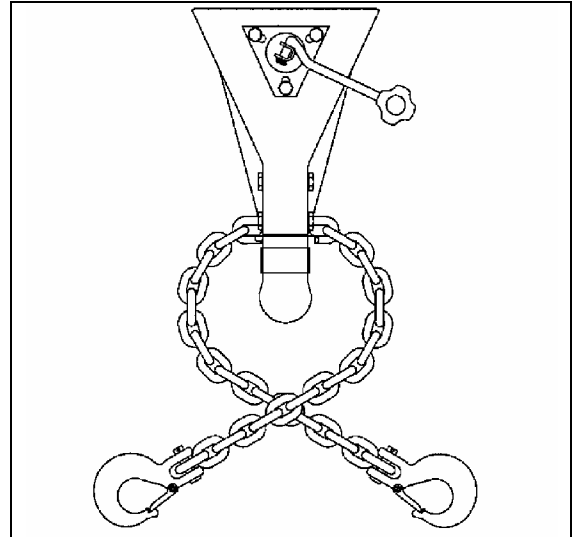

Proper Safety Chain Arrangement – Figure 4-4

^WARNING

Improper rigging of the safety chains can result in loss of control of the trailer and tow vehicle, leading to death or serious injury, if the trailer uncouples from the tow vehicle.

- **Fasten chains to frame of tow vehicle. Do not fasten chains to any part of the hitch unless the hitch has holes or loops specifically for that purpose.**
- **Cross chains underneath hitch and coupler with enough slack to permit turning and to hold tongue up, if the trailer comes loose.**

4.3.5 Attach And Test Breakaway Brake System

If the coupler or hitch fails, a properly connected and working breakaway brake system will apply electric brakes on the trailer. The safety chains will keep the tow vehicle attached and as the brakes are applied at the trailer's axles, the trailer/tow vehicle combination will come to a controlled stop.

The breakaway brake system includes a battery, a switch with a pullpin, and a lanyard. Read and follow the instructions here as well as the instructions that have been prepared by the breakaway brake manufacturer. If you do not have these instructions, call 4-Star Trailers at 405-324-7827 for assistance.

The breakaway brake system may be fitted with a “charging” capability that draws power from the tow

vehicle. If the electrical system on your tow vehicle does not provide power to the breakaway brake battery, you must periodically charge the battery.

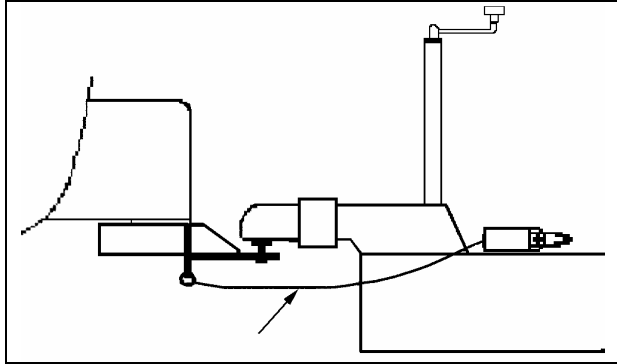

Breakaway Brake Lanyard – Figure 4-5

- Connect the pullpin lanyard to the tow vehicle so that the pullpin will be pulled out before all of the slack in the safety chains is taken up. See figure 4-5. Do **not** connect the pullpin cable to a safety chain or to the hitch ball or hitch ball assembly. This would keep the breakaway brake system from operating when it is needed.
- To test the breakaway brake battery, remove the pullpin from the switch and attempt to pull the trailer forward. You should feel the trailer resisting being towed, but the wheels will not necessarily be locked. If the brakes do not function, do not tow the trailer until brakes, or battery, are repaired.
- Immediately replace the pullpin. The breakaway brake system battery discharges rapidly when the pullpin is removed.

^WARNING

An ineffective breakaway brake system can result in a runaway trailer, leading to death or serious injury if the coupler or ball hitch fails.

Connect the breakaway cable to the tow vehicle; and NOT to the hitch, ball or support.

Before towing the trailer, test the function of the breakaway brake system. If the breakaway brake system is not working, do not tow the trailer. Have it serviced or repaired.

Do **not** tow the trailer with the breakaway brake system ON because the brakes will overheat which can result in permanent brake failure.

^WARNING

Failure to replace the pullpin will prevent brakes from working, leading to loss of control, serious injury or death.

If you do not use your trailer for three or more months, or during winter months:

- Store the battery indoors; and
- Charge the battery every three months.

Replace the breakaway brake battery according to the intervals specified by battery manufacturer.

4.3.6 Connect 7-Pin Electrical Connector

Connect the trailer lights to the tow vehicle's electrical system using the 7-pin electrical connector.

Check all lights for proper operation.

- Clearance and Running Lights (Turn on tow vehicle headlights).
- Brake Lights (Step on tow vehicle brake pedal).
- Turn Signals (Operate tow vehicle directional signal lever).

Check electric brakes for proper operation using brake controller mounted in the cab.

If your trailer has electric brakes, your tow vehicle will have an electric brake controller that sends power to the trailer brakes. Before towing the trailer on the road, you must operate the brake controller while trying to pull the trailer in order to confirm that the electric brakes operate. While towing the trailer at less than 5 m.p.h., manually operate the electric brake controller in the tow vehicle cab. You should feel the operation of the trailer brakes.

^WARNING

Improper electrical connection between the tow vehicle and the trailer will result in inoperable lights and electric brakes, and can lead to collision.

Before each tow:

- Check that the taillights, brake lights and turn signals work
- Check that the electric brakes work by operating the brake controller inside the tow vehicle

4.3.7 Uncoupling The Bumper Pull Trailer

Follow these steps to uncouple your bumper pull trailer from the tow vehicle:

- Park the trailer on a firm level surface.
- Block trailer tires to prevent the trailer from rolling.
- Disconnect the electrical connector.
- Disconnect the breakaway brake switch lanyard.
- Disconnect the safety chains from the tow vehicle.
- Unlock the coupler and open it.
- Before extending jack, make certain the ground surface below the jack pad will support the tongue load.
- Rotate the jack handle (or crank) clockwise. This will extend the jack and transfer the weight of the trailer tongue to the jack.
- Raise the trailer coupler above the tow vehicle ball hitch.

4.4 GOOSENECK TRAILER WITH BALL COUPLER

A gooseneck ball coupler on the trailer connects to a gooseneck ball that you must have installed in the bed of the tow vehicle. See figure 4-6.



Gooseneck Trailer With Ball Coupler – Figure 4-6

We have installed a Gooseneck coupler that is suitable for the size and weight of the trailer. The load rating of the coupler and the necessary ball size are listed on the coupler.

You must provide a gooseneck ball and support structure that is marked with a rating that meets or exceeds the GVWR of your trailer **and** matches the size of the gooseneck ball receiver. If the gooseneck ball is too small, is underrated, is loose or is worn, the trailer can come loose from the tow vehicle, and may lead to death or serious injury.

THE TOW VEHICLE, SUPPORT STRUCTURE AND GOOSENECK BALL MUST HAVE A RATED TOWING CAPACITY EQUAL TO OR GREATER THAN THE TRAILER GROSS VEHICLE WEIGHT RATING (GVWR).

IT IS ESSENTIAL THAT THE GOOSENECK BALL BE OF THE SAME SIZE AS THE GOOSENECK BALL RECEIVER.

The ball size and load rating (capacity) are marked on the ball; hitch capacity is marked on the hitch.

^WARNING

Coupler-to-hitch mismatch can result in uncoupling, leading to death or serious injury.

Be sure the LOAD RATING of the hitch ball is equal or greater than the load rating of the coupler.

Be sure the SIZE of the hitch ball matches the size of the coupler.

A gooseneck trailer will have one or two drop leg jacks for raising and lowering the coupler. See figure 4-7. Because several drop leg jack mechanisms are available, the general instructions below may vary slightly from the jack manufacturer's instructions. If the trailer jack on your trailer does not resemble the jack shown in the figures, follow the jack instructions provided by the jack manufacturer. If you do not have these instructions, call 4-Star Trailers at 405-324-7827 for assistance.



Drop Leg Jack – Figure 4-7

4.4.1 Before Coupling The Trailer To The Tow Vehicle

- Be sure the size and rating of the gooseneck ball match the size and rating of the coupler. Gooseneck balls and couplers are marked with their size and ratings.
- Wipe the gooseneck ball clean and inspect it visually and by feel for flat spots, cracks and pits.

^WARNING

A worn, cracked or corroded gooseneck ball can fail while towing, and may result in death or serious injury.

Before coupling the trailer, inspect the gooseneck ball for wear, corrosion and cracks; and replace worn or damaged gooseneck ball.

- Rock the ball to make sure it is tight to the ball support, and visually check that the gooseneck ball nut is solid against the lock washer and ball support frame.

^WARNING

A loose gooseneck ball can result in uncoupling, leading to death or serious injury.

Be sure the gooseneck ball nut is tight before coupling the trailer.

- Wipe the inside and outside of the coupler clean and inspect it visually for cracks; and feel the inside of the coupler for worn spots and pits. If any of these conditions exist, have the coupler replaced before coupling the trailer.
- Be sure the coupler is tight to the trailer. All coupler fasteners must be visibly solid against the trailer frame.

4.4.2 Prepare The Coupler And Gooseneck Ball

- Lubricate the inside of the coupler with automotive bearing grease.
- Lower the tow vehicle tailgate.
- Rotate the handle/crank clockwise to raise the bottom surface of the coupler to be above the top of the gooseneck ball
- Release the lock plate on the coupler. With the spring-loaded lock plate locking pin in the OPEN position, rotate the lock plate to a position that allows the gooseneck ball to enter the coupler.
- Slowly back up the tow vehicle so that the gooseneck ball is aligned under the coupler.

^WARNING

If the trailer drops during coupling, death or serious injury may result.

There must be no one under the trailer or coupler before or during the coupling operation.

4.4.3 Couple The Trailer To The Tow Vehicle

- Adjust the height of the trailer, using the jack to engage the gooseneck ball and transfer the weight of the trailer tongue to the towing vehicle. If the coupler does not line up with the ball, raise the coupler and adjust the position of the tow vehicle. Then lower the coupler over the ball. When the drop leg base is no longer resting on the ground, the towing vehicle hitch is holding all of the weight of the trailer tongue.
- Visually check that the hitch ball is fully seated in the coupler.
- Move the lock plate on the coupler to the closed position.
- Move the spring-loaded locking pin to the CLOSED position. Be sure the locking pin is holding the lock plate.
- A properly engaged locking mechanism will allow the coupler to raise the rear of the tow vehicle. Using the trailer jack, test to see that you can raise the rear of the tow vehicle by 1 inch.

^Notice

Overloading can damage the drop leg jack. Do not use the drop leg jack to raise the tow vehicle more than 1 inch.

If the gooseneck ball cannot be secured to the receiver, do not tow the trailer. Call your dealer or 4-Star Trailers at 405-324-7827 for assistance.

- After testing to see that the coupler is properly secured and locked to the ball, retract the jack to its fully retracted position.
- Return the drop legs to their upper positions. The drop legs are held in the lowered position with a plunger pin. Rotating the plunger pin while pulling it outward will cause it to come out of engagement with the drop leg and the leg will rapidly rise.

^Caution

The drop legs are heavily spring loaded in the lowered position. They will rapidly return to the upper position when released and can inflict serious bruises, scrapes or pinching.

Keep your feet, shins and hands well clear of the drop legs and drop leg bases when releasing the drop legs.

Always wear shoes or boots while performing this operation

4.4.4 Rig The Safety Chains

- Visually inspect the safety chains and hooks for wear or damage. Replace worn or damaged safety chains and hooks before towing.
- Rig the safety chains so that they attach to the "safety chain receivers" in the bed of the truck. If you are not certain of the hitch provisions for receiving safety chains, contact the hitch manufacturer or installer. Do NOT attach the safety chains to the gooseneck ball or its support; and
- Rig the safety chains so they have sufficient slack to permit turning, but not too much slack – the safety chains must keep the gooseneck on the tow vehicle bed if the trailer uncouples. See figure 4-8.

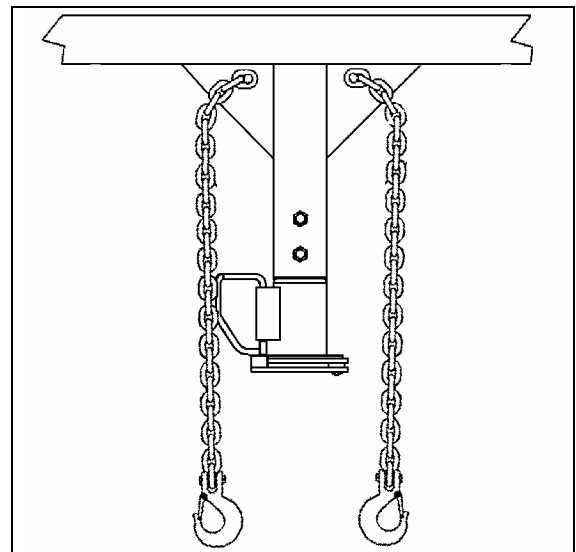

Proper Safety Chain Arrangement – Figure 4-8

^WARNING

Improper rigging of the safety chains can result in loss of control of the trailer and tow vehicle, leading to death or serious injury, if the trailer uncouples from the tow vehicle.

- Fasten chains to safety chain receivers on the hitch, not to ball.
- Have sufficient slack to permit turning and to keep gooseneck on bed of tow vehicle, if the trailer comes loose.

4.4.5 Attach And Test The Breakaway Brake System

If the coupler or hitch fails, a properly connected and working breakaway brake system will apply electric brakes on the trailer. The safety chains will keep the tow vehicle attached and as the brakes are applied, the trailer/tow vehicle combination will come to a controlled stop.

The breakaway brake system includes a battery, a switch with a pullpin, and a breakaway brake controller. Read and follow the instructions here as well as the instructions that have been prepared by the breakaway brake controller manufacturer. If you do not have these instructions, call 4-Star Trailers at 405-324-7827 for assistance.

The breakaway brake system is fitted with a charging facility that draws power from the tow vehicle. If the electrical system on your tow vehicle does not provide power to the breakaway brake battery you must periodically charge the battery on the trailer.

- Visually inspect the breakaway brake system for broken parts.
- Connect the pullpin cable to the tow vehicle so that the pullpin will be pulled out before all of the slack in the safety chains is taken up. See figure 4-9. Do **not** connect the pullpin cable to a safety chain or a safety chain receiver or to the gooseneck ball or its support. This would keep the breakaway brake system from operating when it is needed. Contact the hitch manufacturer or installer if you are not certain of the hitch provisions for breakaway brake connection.

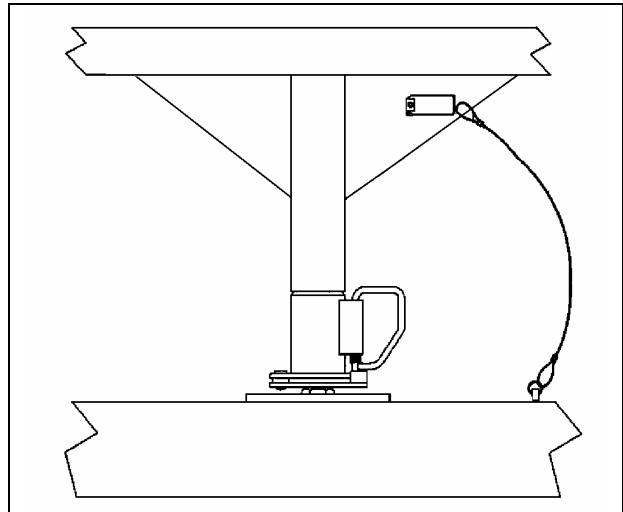

Breakaway Brake Lanyard – Figure 4-9

- To check the breakaway brake battery, pull out the pullpin from the switch and attempt to pull the trailer forward. You should feel the trailer resisting being towed, but the wheels will not necessarily lock up.
- Immediately replace the pullpin. The breakaway brake system battery discharges rapidly when the pullpin is removed.

^WARNING

An ineffective or inoperative breakaway brake system can result in a runaway trailer leading to death or serious injury if the coupler or hitch fails.

Connect the breakaway cable to the tow vehicle; and NOT to the safety chain, safety chain receiver, gooseneck ball or gooseneck ball support.

Test the function of the breakaway brake system before towing the trailer. Do not tow the trailer if the breakaway brake system is not working. Have it serviced or repaired.

Do **not** tow the trailer with the breakaway brake system ON because the brakes will overheat which can result in permanent brake failure.

^WARNING

Failure to replace the pullpin will prevent brakes from working, leading to loss of control, serious injury or death.

Coupling To The Tow Vehicle

If you do not use your trailer for three or more months, or during winter months:

- Store the battery indoors; and
- Charge the battery every three months.

Replace the breakaway brake battery at intervals recommended by the battery manufacturer's instructions.

4.4.6 Connect 7-Pin Electrical Connector

Connect the trailer lights to the tow vehicle's electrical system using the 7-pin electrical connector.

Check all lights for proper operation:

- Clearance and Running Lights (Turn on tow vehicle headlights).
- Brake Lights (Step on tow vehicle brake pedal).
- Turn Signals (Operate tow vehicle directional signal lever).

Check electric brakes for proper operation.

If your trailer has electric brakes, your tow vehicle will have an electric brake controller that sends power to the trailer brakes. Before towing the trailer on the road, you must operate the brake controller while trying to pull the trailer in order to confirm that the electric brakes operate. While towing the trailer at less than 5 m.p.h., manually operate the electric brake controller in the tow vehicle cab. You should feel the operation of the trailer brakes.

^WARNING

Improper electrical connection between the tow vehicle and the trailer will result in inoperable lights and electric brakes, and can lead to collision.

Before each tow:

- **Check that the taillights, brake lights and turn signals work**
- **Check that the electric brakes work by operating the brake controller inside the tow vehicle**

4.4.7 Uncoupling The Gooseneck Trailer With Ball Coupler

Follow these steps to uncouple your gooseneck trailer from the tow vehicle:

- Park the trailer on a firm level surface.
- Lower the tow vehicle tailgate (if equipped).
- Block trailer tires to prevent the trailer from rolling.
- Disconnect the electrical connector.
- Disconnect the breakaway brake switch lanyard.
- Disconnect the safety chains from the tow vehicle.
- Move the spring-loaded coupler lock plate locking pin to the OPEN position.
- Move the lock plate to the open position.
- Before releasing dropleg jack, make certain ground surface below jack base will support the trailer tongue load.
- Rotate the drop leg plunger pin handle so that the plunger pin is released from the drop leg.
- Push down on the drop leg base with your foot to place a drop leg to the desired lowered position.
- Rotate the plunger pin handle so that the plunger pin is attempting to engage the drop leg.
- Slowly raise your foot, permitting the drop leg to raise. The plunger pin will engage a hole in the drop leg.

^Caution

The drop legs are heavily spring loaded in the lowered position. They will rapidly return to the upper position when released and can inflict serious bruises, scrapes or pinching.

Keep your feet, shins and hands well clear of the drop legs and drop leg bases when releasing the drop legs.

Always wear shoes or boots while performing this operation

- Be sure the plunger pin is fully engaged. Push it in by hand if necessary. The bent part of the plunger pin handle must be touching the plunger pin housing.
- If your trailer has two drop leg jacks, lower them both to the same level, following the above instructions.

Error! Not a valid filename.

- Remove the handle (or crank) from its holder and engage it with the jack shaft.
- Rotate the handle (or crank) to slowly extend the jack and transfer the weight of the trailer tongue to the jack.
- On two speed jacks, pushing the handle shaft toward the gearbox can perform rapid extension. This shifts the gearbox into a high speed mode.
- When the drop leg base contacts the ground, shift the gearbox into low gear mode by pulling or

pushing on the handle shaft until it locks into low gear.

^Notice

Do not use high gear to lift the trailer; the drop leg jack mechanism can be damaged.

High gear is used only to rapidly move the drop leg base into contact with the ground.

- Continue to extend the jack(s), making sure that the ground is providing stable and level support for the trailer.
- After the jack(s) are extended and the coupler is well clear of the gooseneck ball, to permit driving the tow vehicle away, disengage the handle from its shaft and return to its holder.
- Move the tow vehicle from under the trailer and raise tailgate.

4.5 GOOSENECK TRAILER WITH KINGPIN

A fifth wheel coupler on the tow vehicle connects to a kingpin that is installed on the trailer. See figure 4-10.

We have installed a kingpin that is suitable for the size and weight of the trailer. You must provide a fifth wheel that matches the kingpin, and that is rated for the Gross Vehicle Weight Rating (GVWR) of the trailer.



Gooseneck Trailer With Kingpin – Figure 4-10

A gooseneck trailer will have one or two drop leg jacks for raising and lowering the kingpin. See figure 4-11. Because several drop leg jack mechanisms are available, the general instructions below may vary

slightly from the jack manufacturer's instructions. If the trailer jack on your trailer does not resemble the jack shown in the figures, follow the jack instructions provided by the jack manufacturer. If you do not have these instructions, call 4-Star Trailers at 405-324-7827 for assistance.



Drop Leg Jack – Figure 4-11

4.5.1 Before Coupling The Trailer To The Tow Vehicle

- Be sure the size and rating of the fifth wheel and kingpin match.
- Wipe the kingpin clean and inspect it visually and by feel for flat spots, cracks and pits. Check the condition of the fifth wheel mounting in the bed of the tow vehicle.

^WARNING

A worn, bent, cracked or corroded kingpin can fail while towing, and may result in death or serious injury.

Before coupling the trailer, inspect the kingpin and kingpin plate for wear, bending, cracks or corrosion; and replace worn or damaged kingpin.

4.5.2 Prepare The Fifth Wheel And Kingpin

- Be sure the fifth wheel mechanism operates freely.
- Lubricate the fifth wheel plate surface with a light coat of Lithium-base, waterproof grease.
- Be sure the fifth wheel and kingpin fasteners are tight and any welds are solid.

Coupling To The Tow Vehicle

^WARNING

A loose fifth wheel or kingpin can result in uncoupling, leading to death or serious injury.

Be sure the fifth wheel and kingpin are tight before coupling the trailer.

- Lower the tow vehicle tailgate (if equipped).
- Be sure the fifth wheel locks are open. Refer to the fifth wheel manufacturers instructions.
- Block the trailer wheels, front and rear.
- Make certain that trailer kingpin plate is slightly above the fifth wheel plate on the tow vehicle.
- Back tow vehicle up close to the trailer, centering the kingpin in the slot of the fifth wheel.
- **STOP** before engaging the coupling.

^WARNING

If the trailer drops during coupling, death or serious injury may result.

There must be no one under the trailer or coupler before or during the coupling operation.

4.5.3 Couple The Trailer To The Tow Vehicle

- Adjust the height of the trailer, using the jack, so that the kingpin plate just touches the fifth wheel plate.
- Slowly back up the tow vehicle, keeping the kingpin centered in the slot of the fifth wheel. Continue backing up until the fifth wheel locks firmly on the kingpin.
- Attempt to pull forward as an initial test of the closing of the fifth wheel locks.
- Visually check to confirm that the fifth wheel locks are properly locked onto the kingpin using the following three checks:
 - Check 1 – The fifth wheel adjustment nut is against the fifth wheel.
 - Check 2 – The secondary lock is behind the yoke.
 - Check 3 – The fifth wheel is against the kingpin plate.

See figure 4-12.

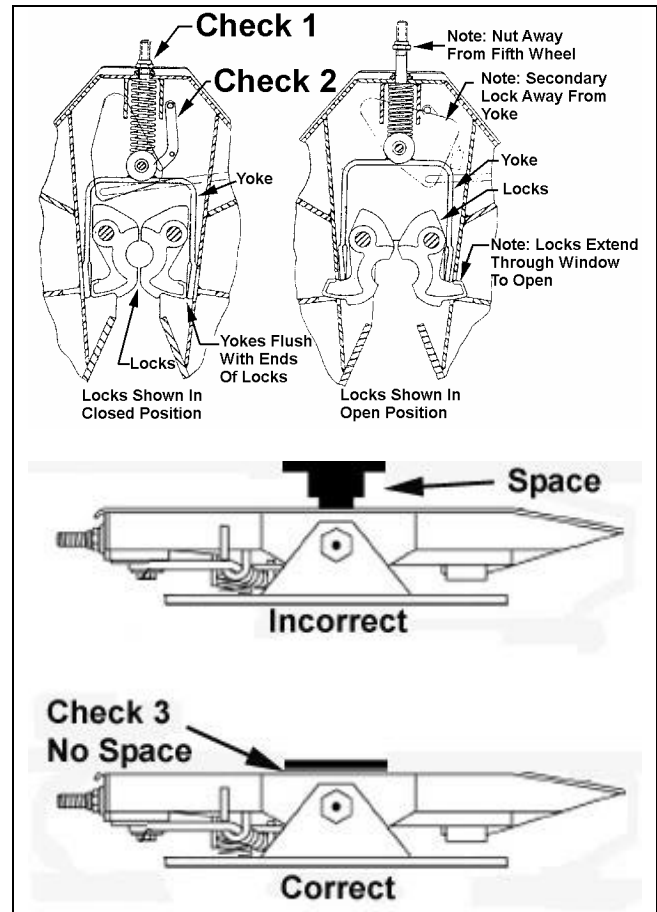

Fifth Wheel And Kingpin Checks – Figure 4-12

^WARNING

An improperly coupled fifth wheel can come loose, resulting in death or serious injury.

Do not tow the trailer until all of the visual checks have been performed:

- **Adjustment nut against fifth wheel.**
 - **Secondary lock behind yoke.**
 - **Fifth wheel against kingpin plate.**
- Rotate the jack handle to slowly retract the jack and transfer the weight of the trailer tongue to the towing vehicle. When the drop leg base is no longer resting on the ground, the towing vehicle hitch is holding all of the weight of the trailer tongue. Continue retracting the jack to its fully retracted position.
 - Return the drop legs to their upper positions. The drop legs are held in the lowered position with a plunger pin. Rotating the plunger pin while pulling it outward about $\frac{3}{4}$ inch will cause it to come out of

the engagement with the drop leg and the leg will rapidly raise.

- Raise the tow vehicle tailgate.
- Pick up the trailer wheel blocks.

^Caution

The drop legs are heavily spring loaded in the lowered position. They will rapidly return to the upper position when released and can inflict serious bruises, scrapes or pinching.

Keep your feet, shins and hands well clear of the drop legs and drop leg bases when releasing the drop legs.

Always wear shoes or boots while performing this operation

4.5.4 Attach And Test The Breakaway Brake System

If the coupler or hitch fails, a properly connected and working breakaway brake system will apply electric brakes on the trailer. The safety chains will keep the tow vehicle attached and as the brakes are applied, the trailer/tow vehicle combination will come to a controlled stop.

The breakaway brake system includes a battery, a switch with a pullpin, and a breakaway brake controller. Read and follow the instructions here as well as the instructions that have been prepared by the breakaway brake controller manufacturer. If you do not have these instructions, call 4-Star Trailers at 405-324-7827 for assistance.

The breakaway brake system is fitted with a charging facility that draws power from the tow vehicle. If the electrical system on your tow vehicle does not provide power to the breakaway brake battery you must periodically charge the battery on the trailer.

- Visually inspect the breakaway brake system for broken parts.
- Connect the pullpin cable to the tow vehicle so that the pullpin will be pulled out before all of the slack in the safety chains is taken up. **Do not** connect the pullpin cable to a safety chain or a safety chain receiver or to the fifth wheel or its support. This would keep the breakaway brake system from operating when it is needed. Contact the hitch

manufacturer or installer if you are not certain of the hitch provisions for breakaway brake connection.

- To check the breakaway brake battery, pull out the pullpin from the switch and attempt to pull the trailer forward. You should feel the trailer resisting being towed, but the wheels will not necessarily lock up.
- Immediately replace the pullpin. The breakaway brake system battery discharges rapidly when the pullpin is removed.

^WARNING

An ineffective or inoperative breakaway brake system can result in a runaway trailer leading to death or serious injury if the coupler or hitch fails.

Connect the breakaway cable to the tow vehicle; and NOT to the safety chain, safety chain receiver, gooseneck ball or gooseneck ball support.

Test the function of the breakaway brake system before towing the trailer. Do not tow the trailer if the breakaway brake system is not working. Have it serviced or repaired.

Do not tow the trailer with the breakaway brake system ON because the brakes will overheat which can result in permanent brake failure.

^WARNING

Failure to replace the pullpin will prevent brakes from working, leading to loss of control, serious injury or death.

If you do not use your trailer for three or more months, or during winter months:

- Store the battery indoors; and
- Charge the battery every three months.

Replace the breakaway brake battery at intervals recommended by the battery manufacturer's instructions.

4.5.5 Connect 7-Pin Electrical Cable

Connect the trailer lights to the tow vehicle's electrical system using the electrical connectors.

Check all lights for proper operation:

- Clearance and Running Lights (Turn on tow vehicle headlights).
- Brake Lights (Step on tow vehicle brake pedal).
- Turn Signals (Operate tow vehicle directional signal lever).

Check electric brakes for proper operation.

If your trailer has electric brakes, your tow vehicle will have an electric brake controller that sends power to the trailer brakes. Before towing the trailer on the road, you must operate the brake controller while trying to pull the trailer in order to confirm that the electric brakes operate. While towing the trailer at less than 5 m.p.h., manually operate the electric brake controller in the tow vehicle cab. You should feel the operation of the trailer brakes.

^WARNING

Improper electrical connection between the tow vehicle and the trailer will result in inoperable lights and electric brakes, and can lead to collision.

Before each tow:

- **Check that the taillights, brake lights and turn signals work**
- **Check that the electric brakes work by operating the brake controller inside the tow vehicle**

4.5.6 Uncoupling The Gooseneck Trailer With Kingpin

Follow these steps to uncouple your fifth wheel hitch trailer from your tow vehicle:

- Block trailer tires to prevent the trailer from rolling before jacking the trailer up.
- Disconnect the electrical connector.
- Disconnect the breakaway brake switch lanyard.
- If the tow vehicle has a tailgate, lower it.
- Make certain that ground surface below jack base will support trailer tongue load.
- Rotate the drop leg plunger pin handle so that the plunger pin is released from the drop leg.
- Push down on the drop leg base with your foot to place a drop leg to the desired lowered position.

^Caution

The drop legs are heavily spring loaded in the lowered position. They will rapidly return to the upper position when released and can inflict serious bruises, scrapes or pinching.

Keep your feet, shins and hands well clear of the drop legs and drop leg bases when releasing the drop legs.

Always wear shoes or boots while performing this operation

- Rotate the plunger pin handle so that the plunger pin is attempting to engage the drop leg.
- Slowly raise your foot, permitting the drop leg to raise. The plunger pin will engage a hole in the drop leg.
- Be sure the plunger pin is fully engaged. Push it in by hand if necessary. The bent part of the plunger pin handle must be touching the plunger pin housing.
- If your trailer has two drop leg jacks, lower them both to the same level, following the above instructions.

^Notice

If the drop legs are not set at the same level, one of the drop leg jacks can be overloaded and can be damaged.

- Release the handle (or crank) from its holder and engage it with the jack shaft.
- Rotate the handle (or crank) clockwise to slowly extend the jack and transfer the weight of the trailer tongue to the jack.
- On two speed jacks, pushing the handle shaft toward the gearbox can perform rapid extension. This shifts the gearbox into a high speed mode.
- When the drop leg base contacts the ground, shift the gearbox into low speed mode by pulling out on the handle shaft until it locks into low gear.

^Notice

Do not use high gear to lift the trailer; the drop leg jack mechanism can be damaged.

High gear is used only to rapidly move the drop leg base into contact with the ground.

Coupling To The Tow Vehicle

- Continue to extend the jack(s), making sure that the ground is providing stable and level support for the trailer.
- Turn the crank two or three turns to take some of the weight of the coupling. Do **not** raise the fifth wheel off the kingpin plate.
- After the jack(s) are extended enough to permit driving the tow vehicle away, disengage the jack handle from its shaft and return it to its holder. Do NOT drive the tow vehicle yet!
- Open the fifth wheel locks by pulling the release handle.
- Slowly drive the tow vehicle away from the trailer.
- Raise the tow vehicle tailgate.

4.6 ADJUST GOOSENECK COUPLER OR KINGPIN HEIGHT

The height of the ball coupler or kingpin on the trailer must be adjusted so that the trailer, when loaded to rated capacity, is level while connected to the tow vehicle. A level trailer allows equal weight distribution on the axles. There must also be adequate clearance between the bottom of the trailer and the sides of the tow vehicle bed.

- Connect trailer to tow vehicle (see Coupling To The Tow Vehicle) and load the trailer to rated capacity (see Loading The Trailer).
- Park the tow vehicle and trailer on a firm level surface. Stand back from the trailer and visually verify if the trailer is level front-to-rear. If the front of the trailer is higher than the rear, the coupler must be retracted. If the front of the trailer is lower than the rear, the coupler must be extended.
- Uncouple trailer from tow vehicle (See Coupling To The Tow Vehicle).
- Loosen the jam nut and setscrew (A). Remove safety lock pin (B) and load bearing pin (C). Extend or retracted the coupler as needed. See figure 4-13.
- Fully insert load bearing pin (C) through both inner and outer tubes and install safety lock pin (B). Tighten setscrew (A) to 75-100 lb. ft. of torque. Tighten jam nut to 80-90 lb. ft. of torque.
- **Never use the setscrew or any other device as a replacement for the load bearing pin (3).**
- **Never cut or drill additional holes in coupler tubes.**

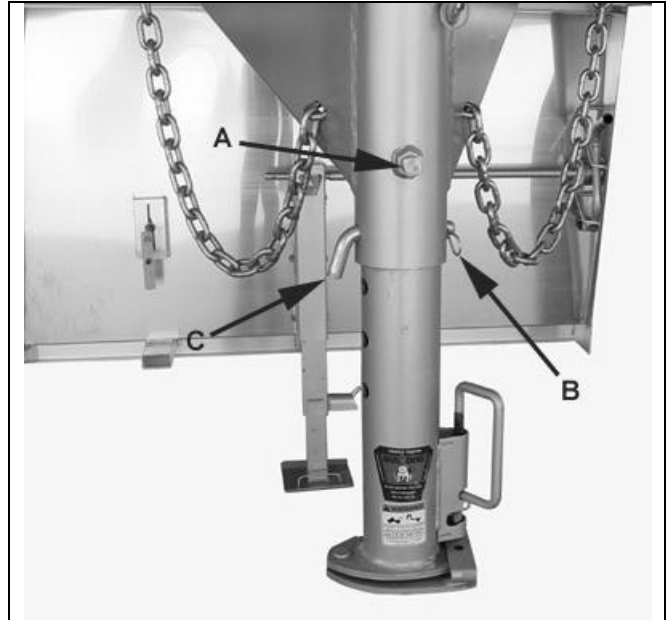

Adjust Gooseneck Coupler or Kingpin Height – Figure 4-13

5. LOADING THE TRAILER

Improper trailer loading causes many accidents and deaths. To safely load a trailer, you must consider:

- Overall load weight;
- Load weight distribution;
- Proper tongue weight; and
- Securing the load properly.

To determine that you have loaded the trailer within its rating, you must consider the *distribution* of weight, as well as the total weight of the trailer and its contents. The trailer axles carry most of the total weight of the trailer and its contents (Gross Vehicle Weight, or "GVW"). The remainder of the total weight is carried by the tow vehicle hitch. It is essential for safe towing that the trailer-tongue and tow vehicle hitch carry the proper amount of the loaded trailer weight, otherwise the trailer can develop an undesirable sway at towing speeds, or the rear of the towing vehicle can be overloaded.

The load distribution must be such that no component part of the trailer is loaded beyond its rating. This means that you must consider the rating of the tires, wheels and axles. For tandem and triple axle trailers, you must make sure that the front-to-rear load distribution does not result in overloading any axle.

Towing stability also depends on keeping the center of gravity as low as possible. Load heavy items on the floor and over the axles. When loading additional items, be sure to maintain even side-to-side weight distribution and proper tongue weight. The total weight of the trailer and its contents must never exceed the total weight rating of the trailer (Gross Vehicle Weight Rating, or "GVWR").

^WARNING

An overloaded trailer can result in loss of control of the trailer, leading to death or serious injury.

Do not exceed the trailer Gross Vehicle Weight Rating (GVWR) or the Gross Axle Weight Rating (GAWR).

Do not load a trailer so that the weight on any tire exceeds its rating.

exert a downward force on the hitch. This is necessary for two reasons. First, the proper amount of tongue weight is necessary for the tow vehicle to be able to maintain control of the tow vehicle/trailer system. If, for example, the tongue exerts an upward pull on the hitch, instead of pushing down on it (because the trailer is overloaded behind its axle(s)), the rear wheel of the tow vehicle can lose traction or grip and cause loss of control. Also, even if there is some weight on the tongue, but not enough weight on the tongue, the trailer can become unstable at high speeds. Remember, the faster you go the more likely the trailer is to sway.

If, on the other hand, there is too much tongue weight, the tow vehicle is prone to jack-knife. Furthermore, the front wheels of the tow vehicle can be too lightly loaded and cause loss of steering control and traction, if the front wheels are driving.

In addition to tow vehicle control, tongue weight is necessary to insure that the trailer axle(s) do not exceed their Gross Axle Weight Rating (GAWR).

The table below has "rules of thumb" for proper tongue weight.

In the table below, the second column notes the rule of thumb percentage of total weight of the trailer plus its cargo (Gross Vehicle Weight, or "GVW") that should appear on the tongue of the trailer. For example, a trailer with a gooseneck hitch, with a loaded weight of 12,000 pounds, should have 20-25% (of 12,000 pounds) on the tongue. That is, the example trailer would have 2,400 to 3,000 pounds on its tongue.

5.1 TONGUE WEIGHT

It is critical to have a portion of the trailer load carried by the tow vehicle. That is, the trailer tongue must

Loading The Trailer

Tongue Weight as a Percentage of Loaded Trailer Weight	
Type of Hitch	Percentage
Ball Hitch (or Bumper Hitch)	10–15% for large trailers
	6-10% for smaller utility and cargo trailers
	4-6% for boat trailers
Gooseneck Hitch	20–25%
Fifth Wheel Hitch	

trailer's axle weight. Simply subtract the axle weight from the total weight to determine the hitch weight.

While you are at the scale, you should weigh the entire combination vehicle. This result should be less than the Gross Combined Weight Rating (GCWR) for your towing vehicle. Some scales allow you to get individual axle weights also. If this is possible, get the tow vehicles front and rear axle weights to make sure they are in the same proportion as the tow vehicle alone, and that the rear axle is not overloaded. This is the best way to check that a weight distribution (or load leveling) hitch is adjusted properly, i.e., you have the proper number of chain links attached to the snap-up brackets.

5.4 SECURING THE CARGO

Since the trailer "ride" can be bumpy and rough, you must secure your cargo so that it does not shift while the trailer is being towed.

^WARNING

Improper tongue weight (load distribution) can result in loss of control of the trailer, leading to death or serious injury.

Make certain that tongue weight is within the allowable range.

Be sure to:

- **Distribute the load front-to-rear to provide proper tongue weight (see chart);**
- **Distribute the load evenly, right and left, to avoid tire overload; and**
- **Keep the center of gravity low.**

^WARNING

Shifting cargo can result in loss of control of the trailer, and can lead to death or serious injury.

Tie down all loads with proper sized fasteners, ropes, straps, etc.

5.5 LOADING AN ENCLOSED TRAILER

Couple the trailer to the tow vehicle before loading. The tongue of a bumper pull trailer can rise during loading, before the cargo is properly distributed. To measure the tongue weight, you will have to uncouple the trailer after it is loaded.

Do not transport people, containers of hazardous substances, cans or containers of flammable substances. However, fuel in the tank of an off-road vehicle, or a car or motorcycle, etc., may be carried inside of your enclosed cargo trailer.

^WARNING

Do not transport people inside the trailer, even if it has living quarters. The transport of people puts their lives at risk and may be illegal.

5.2

5.3 CHECKING TONGUE WEIGHT

To check the tongue weight, the tow vehicle and trailer must be on level ground, as they will be when the trailer is being towed.

The best method of weighing your trailer is to go to a truck stop where there is a "certified" scale. Pull only the tow vehicle onto the scale and get the weight. This weight must be less than your tow vehicle's GVWR. Pull the trailer onto the scale and decouple it from the tow vehicle, leaving just the trailer on the scale. Get a "ticket", which lists the total trailer weight. Re-connect the trailer to your tow vehicle and the drive the tow vehicle wheels off the scale, just leaving the trailer axles on the scale. Get a second "ticket", which lists the

^WARNING

Do not transport flammable, explosive, poisonous or other dangerous materials in your trailer.

5.5.1 Preparing Trailer For Loading

Before loading cargo into your enclosed trailer, inspect the interior of the trailer.

Enclosed trailers may be fitted with “D”-ring hold-downs, and/or a track system that can be used to secure the cargo. Inspect the “D”-rings and track system for looseness or signs of bending before loading the cargo onto the trailer.

^WARNING

Damaged or loose ‘D’-rings can break, allowing cargo to become loose inside the trailer. Loose cargo can shift the center of gravity, and result in loss of control of the trailer.

Inspect “D”-rings, and test them for looseness before loading cargo.

Do not use a damaged or loose “D”-ring to secure cargo.

5.5.2 Loading the Enclosed Trailer

Enclosed trailers may be fitted with a drop ramp door. The weight of the drop ramp door is partially held by a spring and cable counterbalance assembly. If the spring and cable counterbalance assembly is out of adjustment or worn out, it will not provide the expected assistance for slow and careful lowering and raising of ramp.

^WARNING

A spring and cable counterbalance can inflict serious injury if it breaks, or if incorrectly adjusted.

Inspect the cable and cable ends each time the door is operated.

Do not attempt to service the counterbalance. Take the trailer to your dealer for service.

- Carefully lower the drop ramp to the ground.
- Load the cargo up the drop ramp and into the trailer, with approximately 60% of the cargo in the front half of the trailer. If the trailer has living quarters, the cargo area of your trailer will have ventilation openings near the floor. Do not block these ventilation openings. These openings are provided to exhaust potentially deadly fumes.

^WARNING

Accumulation of hazardous fumes can cause death or serious injury.

Do not block access to ventilation ports.

- Secure the cargo to the trailer using appropriate straps, chains and tensioning devices.
- Close the drop ramp door and secure the trailer door catch using a linchpin or other locking device, so that the catch and door cannot open while the trailer is being towed.

^WARNING

If the door opens, your cargo may be ejected onto the road, resulting in death or serious injury to other drivers.

Always secure the door latch after closing. Place a linchpin in the catch.

5.6 LOADING HORSE TRAILER

Couple the trailer to the tow vehicle before loading. This is essential for the bumper pull trailer because the tongue of a bumper pull trailer can rise during loading, before the cargo is properly distributed.

The cargo-carrying portion of a horse trailer is designed only for carrying horses. Do not transport people,

livestock, containers of hazardous substances, or containers of flammable substances.

^WARNING

Do not transport people inside the trailer, even if it has living quarters. The transport of people puts their lives at risk and may be illegal.

^WARNING

Do not transport flammable, explosive, poisonous or other dangerous materials in your trailer.

^WARNING

Do not carry "loose" livestock in your horse trailer. They can cause the trailer to become unstable and can result in loss of control.

You must use a trailer designed to carry "loose" livestock.

Before loading a horse in your trailer, inspect the interior of the trailer. The interior of the trailer must be smooth, and have no protruding objects. There should be no loose objects that could move about and startle or injure the horse. Check the walls, floor, dividers, etc., for loose and broken parts, welds, hinges, etc.

5.6.1 Preparing Horse Trailer For Loading

- Open windows and vents to provide ventilation. Consider the weather and transport conditions (i.e. on warm sunny days, maximum ventilation is required). Do not carry a horse without providing ventilation, even in coldest weather. Ventilation is critical for the well being of your horses. Know your horses and adjust ventilation for your horses' comfort.
- Be sure pivoting window latches are in a flush position, so they do not present a protrusion that can injure your horse.
- Tighten any loose or protruding screws in the walls.
- Remove or secure loose objects, (i.e. butt bars, saddles, tack and equipment) so that items will not move during towing.

- Inspect for cracks at the welds on the divider hinges, and the welds on the tie rings. If you are able to open any cracks in or near these welds by lifting the dividers or by twisting the tie rings, have the weld repaired before loading your horses.

^Caution

The trailer interior may contain hazards to a horse that can result in its serious injury or death.

Before loading a horse, inspect the trailer interior and adjust or repair all loose and protruding features such as handles, loose or broken parts of the trailer, etc.

Before towing trailer:

- **Lock all stall dividers.**
- **Be sure all saddles, tack and equipment, as well as horse(s), are prevented from being thrown about.**

^WARNING

Improper weld repair will lead to early failure of the trailer structure and can cause serious injury or death.

Do not repair cracked or broken welds unless you have the skills and equipment to make a proper repair. Have the welds repaired by your dealer.

5.6.2 Loading Horse Trailer

The trailering of horses introduces many variables that are not present in the trailering of non-living cargo. Horses are prone to take flight when they feel threatened or pain. In the confines of a trailer, the flight response can cause serious injury or death to a human handler. Even experienced and docile horses can be frightened.

Horses must be slowly acclimated to trailering. Be sure the horse's first trips are short trips, so you can gauge its reaction. Some will take to the experience easily, but others will strongly protest. You must act according to your horse's demeanor.

^WARNING

When a horse is frightened, it is capable of inflicting serious injury or death to a human handler.

Know your horse's temperament before attempting to trailer it.

Handling a horse that is not trailer-acclimated may result in injury or death, or damage to your trailer.

Do not haul an unbroken horse in this trailer.

Horses must have a halter.

- Open all stall dividers and lock them in their OPEN (against the wall) position.
- If the trailer has living quarters, close and lock the door between the living quarters and the horse area.
- If the trailer is fitted with a drop ramp, carefully lower it to the ground.
- If your trailer is fitted with swinging loading doors, open them fully and fasten them against the side of the trailer using the door holdbacks.
- Lead the horse into the trailer by a halter or lead rope. If the horse shows any signs of distress, stop loading, and calm the horse.

^WARNING

Improper weight distribution of the horses in the trailer will result in an unstable trailer.

Always load the first horse into the forward-most stall.

- Tie the horse to the trailer interior by fastening the quick connect or tying the lead rope to the tie ring, or other facility provided on the trailer wall for attachment of the lead rope. A rule of thumb is to leave about 18 inches of free rope between the attachment point on the trailer and the horse. The layout of the horse trailer has been designed to safely contain your horse. The trailer is equipped with stall dividers and tie rings to secure the horse, and has a rubber floor mat to keep shod horses from slipping on the metal underfloor. Restraining a horse without using a combination of a tie-strap and stall divider may result in serious injury or death to the horse.

^Caution

Failure to secure a horse using a tie strap may result in its serious injury or death.

- Close and lock the stall divider. See figure 5-1.



Stall Divider Closed and Locked - Figure 5-1

- If additional horses are to be loaded, repeat steps above for each horse – lead the horse, secure the horse, close and lock the stall divider.
- After the last horse has been loaded, lock any unused dividers in the CLOSED (across the trailer) position.
- Double check that each horse is tied to the trailer and each stall divider is LOCKED in the CLOSED position.
- If your trailer is fitted with a butt bar or butt strap to keep the horse away from the door, hook and lock the butt bar in place.
- Close the trailer. Remove the door holdbacks and swing the hinged doors to a closed position, or raise the drop ramp.
- Secure the trailer door catch with a linchpin or similar device, so that the catch and door cannot open while the trailer is being towed.
- Close and secure the trailer feed doors.

^WARNING

If the door opens, your cargo may be ejected onto the road, resulting in death or serious injury to other drivers.

Always secure the door latch after closing. Place a linchpin in the catch.

- Check the horses after 5 to 10 miles or 10 minutes of towing, and then at least once per hour thereafter. Open a feed door or other access and look for signs of stress, cuts, or injury. On long trips it is recommended that horses be removed from the trailer every 6-10 hours for exercise, food and watering.

^WARNING

Horses may kick when back door is opened.

Stay clear when opening back door.

5.7 LOADING LIVESTOCK

Couple the trailer to the tow vehicle before loading. This is essential for the bumper pull trailer because the tongue of a bumper pull trailer can rise during loading, before the cargo is properly distributed.

The cargo-carrying portion of a livestock trailer is for carrying livestock (other than horses) only. The livestock trailer does not have the equipment required for the safe transport of horses, e.g. stall dividers, tie rings and a rubber floor mat. Do not transport people, containers of hazardous substances, or containers of flammable substances.

^WARNING

Do not transport people inside the trailer, even if it has living quarters. The transport of people puts their lives at risk and may be illegal.

^WARNING

Do not transport flammable, explosive, poisonous or other dangerous materials in your trailer.

^Caution

Hauling a horse in a livestock trailer may result in its serious injury or death.

Do not carry a horse in a livestock trailer. Use a trailer designed to carry horses.

5.7.1 Preparing Livestock Trailer For Loading

- Before loading livestock in your livestock trailer, inspect the interior of the trailer. The interior of the trailer must be smooth, and have no protruding objects, such as bolts, broken parts of trailer interior, etc. A protruding object can injure your livestock.
- Tighten any loose or protruding bolts in the walls.
- Remove or secure loose objects, so no items will move during towing.

^Caution

The interior space of a trailer may contain hazards that result in serious injury or death to trailered livestock.

Inspect the interior of the trailer before loading livestock.

- **Adjust or repair all loose and protruding features.**
- **All cargo and equipment, besides the livestock, must be prevented from being thrown about before towing trailer.**

5.7.2 Loading Livestock Trailer

The trailering of livestock introduces many variables that are not present in the trailering of non-living cargo. Livestock may resist being loaded into a trailer.

^WARNING

Large animals are capable of inflicting serious injury or death to a human handler.

Know your animals' temperament before attempting to trailer them.

- If the trailer is fitted with a drop ramp, carefully lower it to the ground.
- With the trailer in position, open and secure the loading door (either swinging or roll-up).
- Open and secure the interior gates as necessary.
- Guide the livestock into the trailer.
- Gate the livestock tightly to keep them from moving or falling during transportation.
- Close the loading doors and raise the drop ramp.
- Secure the trailer door catch with a linchpin or similar device, so that the catch and door cannot open while the trailer is being towed.

^WARNING

If the door opens, your cargo may be ejected onto the road, resulting in death or serious injury to other drivers.

Always secure the door latch after closing.
Place a linchpin in the catch.

6. CHECKING THE TRAILER BEFORE AND DURING EACH TOW

6.1 PRE-TOW CHECKLIST

Before towing, double-check all of these items: See section 9.1, "Inspection, Service & Maintenance Summary Charts," for more information.

- Tires, wheels and lug nuts. See "Major Hazards" in the "Safety" section.
- Tire Pressure. Inflate tire on trailer and tow vehicle to the pressure stated on the respective VIN / Certification label.
- Coupler secured and locked. See "Coupling and Uncoupling the Trailer" section.
- Safety chains properly rigged to tow vehicle, not to hitch or ball. See "Coupling to the Tow Vehicle" section.
- Test all lights.
- Test trailer brakes.
- Safety breakaway switch cable fastened to tow vehicle, not to safety chains. See "Coupling to the Tow Vehicle" section.
- Cargo properly loaded, balanced and tied down. See "Loading the Trailer" section.
- Tongue weight and weight distribution set-up.
- Doors and gates latched and secured.
- Fire extinguisher.
- Flares and reflectors.

6.2 MAKE REGULAR STOPS

After each 50 miles, or one hour of towing, stop and check the following items:

- Coupler secured.
- Safety chains are fastened and not dragging.
- Cargo secured.
- Cargo door latched and secured.

7. BREAKING-IN A NEW TRAILER

7.1 RETIGHTEN LUG NUTS AT FIRST 10, 25 & 50 MILES

Wheel lugs can shift and settle quickly after being first assembled, and must be checked after the **first** 10, 25 and 50 miles of driving. Failure to perform this check may result in a wheel coming loose from the trailer, causing a crash leading to death or serious injury.

^WARNING

Lug nuts are prone to loosen after initial installation, which can lead to death or serious injury.

Check lug nuts for tightness on a new trailer or when wheel(s) have been remounted after the first 10, 25 and 50 miles of driving.

See Section 9.2.13 page 59 on Proper Torque Technique.

7.2 ADJUST BRAKE SHOES AT FIRST 200 MILES

Brake shoes and drums experience a rapid initial wear. The brakes must be adjusted after the first 200 miles of use, and each 3,000 miles thereafter. Some axles are fitted with a mechanism that will automatically adjust the brake shoes when the trailer is "hard braked" from a rearward direction. Read your axle and brake manual to see if your brakes adjust automatically. If you do not have the axle and brake manual, call 4-Star Trailers at 405-324-7827 for assistance.

A hard stop is used to:

- Confirm that the brakes work;
- Confirm that the trailer brakes are properly synchronized with the tow vehicle brakes using the brake controller in the tow vehicle
- Adjust the brake shoes as necessary.
- For surge brakes check the Master cylinder reservoir for fluid.

If your trailer is not fitted with automatically adjusting brakes, the brakes will need to be manually adjusted. See section 9.2.5.2, "Manually Adjusting Brake Shoes," for instructions.

7.3 SYNCHRONIZING THE BRAKE SYSTEMS

Trailer brakes are designed to work in synchronization with the brakes on the tow vehicle. When the tow vehicle and trailer braking systems are synchronized, both braking systems contribute to slowing, and the tongue of the trailer will neither dive nor rise sharply.

^WARNING

If trailer and tow vehicle brakes do not work properly together, death or serious injury can occur.

Road test the brakes in a safe area at no more than 30 m.p.h. before each tow

To insure safe brake performance and synchronization, read and follow the axle/brake and the brake controller manufacturers' instructions. If you do not have these instructions, call 4-Star Trailers at 405-324-7827 for assistance.

7.4 TIRE PRESSURE

Check tire pressures on both the trailer and tow vehicle. Inflate to the maximum shown on the respective VIN / Certification Label.

8. ACCESSORIES

This chapter provides some basic information for the safe operation of several accessories. For many accessories, such as generators and LP appliances, the manufacturer of the accessory has also provided instructions. You must read and follow these instructions before using the accessory. If you are uncertain whether you have all of the instructions, call 4-Star Trailers at 405-324-7827 before operating the accessory. The following accessories are described in this section:

- Accessory Battery
- Livestock Gates
- Ramps
- Egress Windows
- Drop Down Feed Doors

Many accessories introduce the risk of fire and carbon monoxide poisoning. If you have an accessory on your trailer, make sure you have a fire extinguisher charged and ready before operating the accessory. Check the fire extinguisher at least once a month. If the fire extinguisher is discharged even partially, it must be recharged. Follow the fire extinguisher manufacturer's instructions for recharging the extinguisher after use.

8.1 ACCESSORY BATTERY

Your trailer may be outfitted with an accessory battery that operates lighting, electric landing gear, slide-outs or other accessories. An accessory battery may be kept charged either by the tow vehicle or by an auxiliary battery charger.

A disconnect switch may be provided to disconnect the accessory battery when you do not plan to be using the trailer for an extended period, such as seasonal storage. If there is no disconnect switch, then remove the cables from the battery terminals.

The accessory battery must be kept in a charged condition during storage. The battery could freeze and break if it becomes discharged.

8.2 LIVESTOCK GATES

Your trailer may be equipped with one or several center gates. Center gates may be adjustable.

Livestock center gates are normally equipped with a slam latch. The gate is equipped with an inside and an outside release. Do not open center gates from the inside of the trailer with live animal(s) loaded.

^WARNING

If trailer and tow vehicle brakes do not work properly together, death or serious injury can occur.

Road test the brakes in a safe area at no more than 30 m.p.h. before each tow

To open, pull down on release handle (A). See figure 8-1. If opening from the inside, swing the gate open to curb side and secure with catch (B). See figure 8-2.



Livestock Gate Inside Release Handle – Figure 8-1

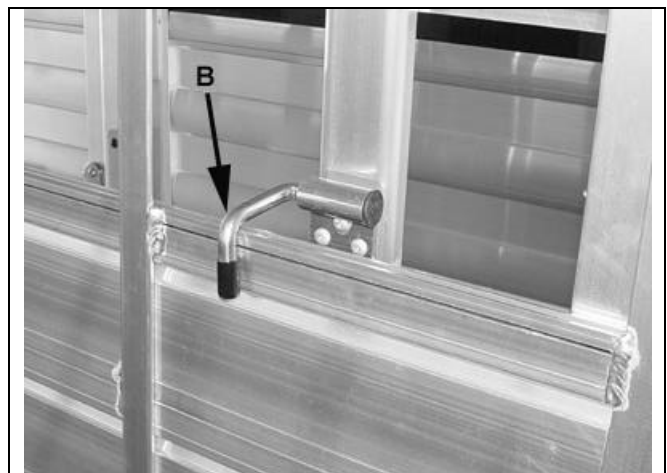

Center Livestock Gate Catch – Figure 8-2

To open center gate from the outside, turn release handle (C) clockwise. See figure 8-3.

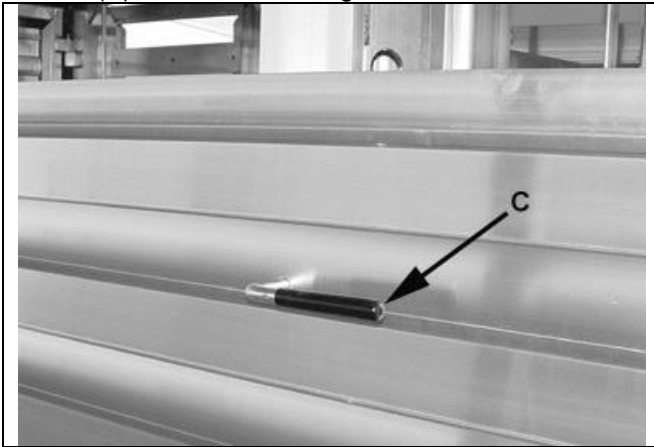

Livestock Gate Outside Release Handle – Figure 8-3

To reposition an adjustable center gate, pull and hold the cable (D) located on the outside of the post to release locks. See figure 8-4. Position the post as needed and release cable. Move post forward or rearward to engage locks. Repeat for post on the opposite side of trailer.



Adjustable Livestock Gate – Figure 8-4

8.3 REAR RAMP OVER DOORS

Your trailer may be equipped with a rear ramp over rear doors. See figure 8-4. The ramp is spring loaded to assist in opening and closing. Open latches (A) and lower ramp. See figures 8-5 and 8-6.



Rear Ramp Closed – Figure 8-5

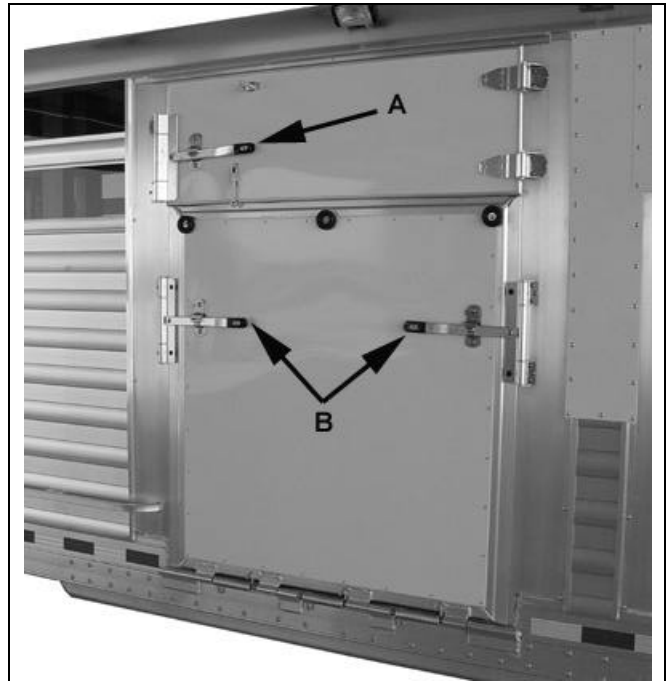

Side Ramp And Door Closed – Figure 8-7



Rear Ramp Open – Figure 8-6



Side Ramp And Door Open – Figure 8-8

8.4 SIDE RAMP

Your trailer may be equipped with a full height side ramp door or a door with a partial ramp as shown. See figure 8-7. The ramp is spring loaded to assist in opening and closing.

Open latch (A), open top door fasten with tie back. Open latches (B) and pull down on ramp. See figure 8-8.

8.5 EGRESS WINDOW

One or more egress windows can be installed if the trailer is to have a living quarters installed, or are optional in the tack/dressing room.

Egress windows can be opened and used as an exit in an emergency. To open, pull out on the red latches (A) and push out on the bottom of the window. See figure 8-9.



Egress Window – Figure 8-9

8.6 DROP DOWN FEED DOORS

The drop down feed doors are made with a sliding window and can be equipped with an optional drop down safety grill.

The drop down safety grill makes traveling in high temperatures more moderate, allowing ample air flow through the trailer. Do not attach or tie animals, feed equipment or tack directly to the grill.

Open the drop down feed door by pulling out on the latch located at the bottom center of the door. Pull door down to expose the optional safety grill. See figure 8-10.



Drop Down Feed Door – Figure 8-10

The safety grill can also be dropped down to allow feeding or total head exposure while parked. Raise the feed door slightly until the safety bar grill tab (A) is aligned with the opening in the guide and then pull safety grill outward. See figure 8-11.

Never leave the safety grill down or open while traveling. Return the safety bar grill back to closed position by inserting the grill tab (A) back into the opening in the guide.

Caution

Hauling a horse in a livestock trailer may result in its serious injury or death.

Do not carry a horse in a livestock trailer. Use a trailer designed to carry horses.

Close the drop down feed door by swinging the door back up into the opening and engaging latch.

Always keep one hand in contact with feed door while closing. Check the paddle of the door latch after shutting the door to insure that it is not loose. A paddle that can be jiggled is an indication the latch bolt is not fully engaged in the striker.

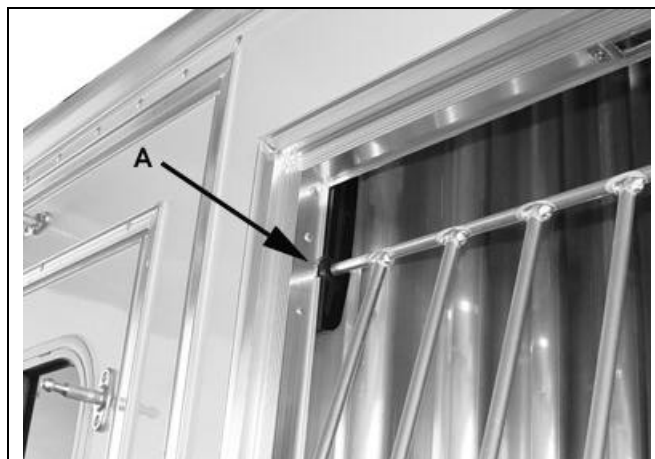

Safety Grill – Figure 8-11

9. INSPECTION, SERVICE & MAINTENANCE

9.1 INSPECTION, SERVICE & MAINTENANCE SUMMARY CHARTS

You must inspect, maintain and service your trailer regularly to insure safe and reliable operation. If you cannot or are unsure how to perform the items listed here, have your dealer do them. Note: In addition to this manual, also check the relevant component manufacturer's manual.

Inspection and Service Before Each Use		
Item	Inspection / Service	Manual Section Reference
Breakaway Brakes > Electric > Hydraulic	Check operation Check fluid level	Sections 4.3.5, 4.4.5 & 4.5.5 Section 9.2.5.4
Breakaway Battery	Fully charged, connections clean	Sections 4.3.5, 4.4.5 & 4.5.5 Section 9.2.5.3
Brakes, all types	Check operation	Section 7.3
Shoes and Drums	Adjust	Section 7.2 & 9.2.5.2
Brakes, Hydraulic – Vacuum Actuated	Check gauge for proper vacuum of 18 In. Hg. (inches of mercury)	Section 9.2.5.4
Coupler and Hitch Ball	Check for cracks, pits, and flats. Replace w/ball & coupler having trailer GVW Rating. Grease. Check locking device & replace.	Section 4.3.2 & 9.2.6.1
Gooseneck Ball	Check for cracks, pits, and flats. Replace w/ball & coupler having trailer GVW Rating. Grease. Check locking device & replace when worn.	Section 4.4.2 & 9.2.6.2
Fifth Wheel & Kingpin	Check for cracks, Grease. Check locking device & replace when worn.	Section 4.5.2 & 9.2.6.3
Safety Chain(s) & Hooks	Check for wear and damage	Sections 4.3.4 & 4.4.4
Tires	Check tire pressure when cold. Inflate as needed.	Sections 1.1 & 9.2.10
Wheels - Lug Nuts (Bolts) & Hub	Check for tightness Tighten. For new and remounted wheels, check torque after first 10, 25 & 50 miles of driving and after any impact	Section 1.1 Sections 1.1 & 9.2.13

Service, Maintenance and Inspections

Inspection and Service Before Each Use

Item	Inspection / Service	Manual Section Reference
Livestock Trailer Center Gate Latches	Remove manure, etc.	Section 9.2.2.3

Inspection and Service each 3 Months or 3,000 Miles

Item	Inspection / Service	Manual Section Reference
Structure	Remove mats. Wash both sides. Wash floor	Section 9.2.2
> Rubber mats and floor		
> Hinges, Doors and dividers	Inspect. Repair or replace damaged, worn or broken parts	Sections 5.6.1, 5.7.1 & 9.2.2

Inspection and Service each 6 Months or 6,000 Miles

Item	Inspection / Service	Manual Section Reference
Tires	Rotate @ 5,000 miles	Section 9.2.10
Brakes, electric		
> Magnets	Check wear and current draw	Section 9.2.5.3
> Controller (in tow vehicle)	Check power output (amperage) and modulation	Section 9.2.5.3 See Controller Mfr's Manual
Structure		
> Roof Vents	Clean dirt buildup, lubricate hinges and slides	Section 9.2.2
> Windows		
Tires	Inspect tread and sidewalls thoroughly. Replace tire when treads are worn, when sidewall has a bulge, or sidewall is worn	Section 9.2.10 Section 9.2.10

Inspection and Service Each Year or 12,000 Miles

Item	Inspection / Service	Manual Section Reference
Brakes, all types	Check for scoring and wear. Replace per manufacturer's specifications	Section 9.2.5.1 See Brake Mfr's Manual
> Shoes and drums		
Jack, Drop-leg	Grease gears at top	See Jack Mfr's Manual
Structure		
> Frame members	Inspect all frame members, bolts & rivets. Repair or replace damaged, worn or broken parts.	Section 9.2.1
> Welds	Inspect all welds. Repair as needed	Section 9.2.2.2
> Slide-out	Clean dirt build-up. Lubricate slides, shafts and gears	Section 9.2.4
Wheels	Check and confirm free running. Replace if not (sealed bearings are not serviceable)	Section 9.2.12
> Sealed Bearings (Hubs)		
> UNSEALED Bearings (Hubs)	Disassemble / inspect / assemble and repack. Replace promptly if immersed in water	Section 9.2.12.1 See Axle Mfr's Manual
> Rims	Inspect for cracks & dents. Replace as needed.	Section 9.2.11
Structure		
> Axle Attachment Bolts	Check BY DEALER	Section 9.2.1

9.2 INSPECTION AND SERVICE INSTRUCTIONS

9.2.1 Axle Bolts, Frame, Suspension, & Structure

^WARNING

Worn or broken suspension parts can cause loss of control and injury may result.

Have trailer professionally inspected annually and after any impact.

To perform many of the inspection and maintenance activities, you must jack up the trailer.

When jacking and using jack stands, place them so as to clear wiring, brake lines, and suspension parts (springs, torsion bars, etc.). Place jacks and jack stands inside of the perimeter strip on the supporting structure to which the axles are attached.

^WARNING

Never crawl under your trailer unless it is on firm and level ground and resting on properly placed and secured jack stands.

9.2.2 Trailer Structure

Because the trailer floor receives the most abuse, it will most likely corrode before any other part of the structure. This is particularly true for horse and livestock trailers, having floors subjected to urine and manure. The urine and manure are corrosive to the metal flooring and other structural parts of the trailer.

Remove the rubber mats from the floor of the trailer, and wash them, at least every three months. Using a power washer and a detergent solution, wash both sides of the rubber mat, as well as the floor and walls of the trailer. Rinse the rubber mat and the trailer floor and walls. Be sure the rubber mat and trailer floor are completely dry before replacing the rubber mat.

9.2.2.1 Fasteners And Frame Members

Inspect all of the fasteners and structural frame members for bending and other damage, cracks, or failure. Repair or replace any damaged fastener and repair the frame member. If you have any questions about the condition or method of repair of fasteners or

frame members, get the recommendation of, or have the repair done by, your dealer.

The various fastener types used on your trailer are:

- Bolts, which are used mainly for attaching door and gate hinges to the trailer body;
- Blind Rivets, which are used to attach the sides and roof panels of the body to each other, and to the frame of the trailer;
- Huck Bolts may be at various locations on the sub-frame. Huck bolts are not user serviceable. If you detect a loose huck bolt fastener, do not tow the trailer. Call your dealer for instructions.

^WARNING

Broken or damaged fasteners or welds can cause injury or damage to trailer and contents.

Inspect for, and repair all damaged parts at least once a year.

9.2.2.2 Welds

All welds can crack or fail when subjected to heavy loads or movement of cargo that was not properly tied to prevent movement. Any time that you know or suspect that the trailer has been subjected to heavy loads or movement of cargo, immediately inspect the welds and fasteners for damage. To prevent severe damage to your trailer, inspect all of the welds for cracks or failure at least once a year. If your trailer is equipped with an electric/hydraulic brake actuator, disconnect its ground wire before welding. Failure to disconnect the ground wire **will** damage the unit. Connect ground wire after welding.

^WARNING

Improper weld repair will lead to early failure of the trailer structure and can cause serious injury or death.

Do not repair cracked or broken welds unless you have the skills and equipment to make a proper repair. If not, have the welds repaired by your dealer.

9.2.2.3 Center Gate Latch

The latch used on the livestock trailer center gates must be kept clean to ensure proper operation. Clean

all manure, etc. from latch and lubricate before each use.

9.2.3 Drop Ramp Torsion Springs

If your trailer has a drop-ramp door, the weight of the door may be partially held by a torsion spring and a cable. Stand to the side when opening the drop ramp. You could be hurt if you are behind the drop ramp and the counterbalance does not work.

Inspect the cable and cable ends regularly for fraying and signs of loosening. If released, a torsion spring can inflict serious injury.

The torsion spring and cable are not user serviceable. The torsion spring must be serviced by a person who is trained in torsion spring safety.

9.2.4 Slide-Outs

Follow the manufacturers instructions to maintain the slide-out mechanism. If you do not have this manual, call 4-Star Trailers at 405-324-7827 for assistance.

9.2.5 Trailer Brakes

9.2.5.1. Brake Shoes And Drums

Properly functioning brake shoes and drums are essential to ensure safety. You must have your dealer inspect these components at least once per year, or each 12,000 miles.

The brake shoes must be adjusted after the first 200 miles of use, and each 3,000 miles thereafter. Most axles are fitted with a brake mechanism that will automatically adjust the brake shoes when the trailer is "hard braked" from a rearward direction. Read your axle and brake manual to see how to adjust your brakes. If you do not have this manual, call 4-Star Trailers at 405-324-7827 for assistance.

9.2.5.2. Manually Adjusting Brake Shoes

Some braking systems are not automatically adjusted by hard stopping. These brakes require manual adjustment. The following steps apply to adjust most manually adjustable brakes. Read your axle and brake manual to see how to adjust your brakes. If you do not have this manual, call 4-Star Trailers at 405-324-7827 for assistance.

- Jack up the trailer and secure it on adequate capacity jack stands.
- Be sure the wheel and brake drum rotate freely.
- Remove the adjusting-hole cover from the adjusting slot on the bottom of the brake backing plate.

- With a screwdriver or standard adjusting tool, rotate the starwheel of the adjuster assembly to expand the brake shoes. Adjust the brake shoes out until the pressure of the linings against the drum makes the wheel very difficult to turn. Note: Your trailer maybe equipped with drop spindle axles. See axle manual for your axle type. You will need a modified adjusting tool for adjusting the brakes in these axles. With drop spindle axles, a modified adjusting tool with about an 80 degree angle should be used.
- Rotate the starwheel in the opposite direction until the wheel turns freely with a slight drag.
- Replace the adjusting-hole cover.
- Repeat the above procedure on all brakes.
- Lower the trailer to the ground.

9.2.5.3. Brakes, Electric

Two different types of electric brakes may be present on the trailer: an emergency electric breakaway system, which acts only if the trailer comes loose from the hitch and the breakaway pin is pulled. The other brake is an electric braking system that acts whenever the brakes of the tow vehicle are applied.

The breakaway battery supplies the power to operate the trailer brakes if the trailer uncouples from the tow vehicle. Be sure to check, maintain and replace the battery according to the battery manufacturer' instructions.

This switch causes the breakaway battery to operate the electric brakes if the trailer uncouples from the tow vehicle.

The pull cable for the pull pin is connected to the tow vehicle, and the switch is connected to the trailer. To check for proper functioning of the switch, battery and brakes, you must pull the pin from the switch and confirm that the brakes apply to each wheel. You can do this by trying to pull the trailer with the tow vehicle, after pulling the pin. The trailer brakes may not lock, but you will notice that a greater force is needed to pull the trailer.

^WARNING

If electric breakaway brakes do not operate when trailer is uncoupled from the tow vehicle, death or serious injury can occur.

Check emergency breakaway brake system BEFORE each tow.

Tow Vehicle Operated Electric Brakes

The electric brakes that operate in conjunction with the tow vehicle brakes must be “synchronized” so that braking is properly distributed to the tow vehicle brakes and the trailer brakes. For proper operation and synchronization, read and follow the axle/brake and the brake controller manufacturers’ instructions. If you do not have these instructions, call 4-Star Trailers at 405-324-7827 for assistance.

Magnets for all Electric Brakes

To make certain an electrically-operated braking system will function properly, you must have your dealer inspect the magnets at least once a year, or each 12,000 miles. See the brake manual for wear and current inspection instructions.

9.2.5.4. Brakes, Hydraulic (vacuum, air or electric operated)

If your trailer has hydraulically-operated brakes, they function the same way the hydraulic brakes do on your tow vehicle. The hydraulic braking system must be inspected by a dealer, at least as often as the brakes on the tow vehicle, but no less than once per year. This inspection includes an assessment of the condition and proper operation of the wheel cylinders, brake shoes, brake drums and hubs.

You must check the fluid level in the master cylinder reservoir at least every three months. If you tow your trailer an average of 1,000 miles per month in a hot and dry environment, you must check the brake fluid level once a month. The brake fluid reservoir is located on the tongue of the trailer or near the gooseneck. Fill with DOT 4 brake fluid.

Vacuum-operated hydraulic

When towing a trailer, the vacuum gauge, which is located inside the cab of the tow vehicle, must indicate 18 In. Hg. (inches of mercury) or more at all times.

^WARNING

If the vacuum gauge in tow vehicle is not at or above 18 In. Hg. (inches of mercury), damage to the brake system will result and the brakes may become inoperable.

Air Pressure-Operated Hydraulic

Air/hydraulic braking systems are typically used when the tow vehicle has a diesel engine. The tow vehicle has an air compressor that routes the air to an air/hydraulic mechanism, which sends brake fluid to the wheel cylinders.

The air pressure gauge in your tow vehicle indicates the current air pressure. See your tow vehicle manual for the proper air pressure.

Electrical-operated Hydraulic

Electric/hydraulic braking systems, which are mounted on the trailer, use a small electrically-driven pump to generate hydraulic pressure, which operates the brake cylinders. Like electrical brakes, an electric/hydraulic braking system is operated by an electrical signal from the tow vehicle.

9.2.6 Trailer Connection to Tow Vehicle

9.2.6.1. Bumper Pull Coupler and Ball

The coupler on the trailer connects to the ball attached to the hitch on the tow vehicle. The coupler, ball and hitch transfer the towing forces between the tow vehicle and the trailer. Before each tow, coat the ball with a thin layer of automotive bearing grease to reduce wear and ensure proper operation; and check the locking device that secures the coupler to the ball for proper operation.

See the coupler manufacturer’s manual for other inspection and maintenance activities. If you do not have this manual, call 4-Star Trailers at 405-324-7827 for assistance.

If you see or feel evidence of wear, such as flat spots, deformations, pitting or corrosion, on the ball or coupler, immediately have your dealer inspect them to determine the proper action to prevent possible failure of the ball and coupler system. All bent or broken coupler parts must be replaced before towing the trailer.

The coupler handle lever must be able to rotate freely and automatically snap into the latched position. Oil the pivot points, sliding surfaces, and spring ends with SAE 30W motor oil. Keep the ball pocket and latch mechanism clean. Dirt or contamination can prevent proper operation of the latching mechanism.

When replacing a ball, the load rating must match or exceed the GVWR of the trailer.

9.2.6.2. Gooseneck Coupler and Ball

The gooseneck receiver on the trailer connects to a hitch-mounted ball on the towing vehicle. The receiver, ball and hitch transfer the towing forces between the tow vehicle and the trailer. Before each tow, coat the ball with a thin layer of automotive bearing grease to reduce wear and ensure proper operation; and check the locking device that secures the receiver to the ball for proper operation.

See the gooseneck ball receiver manufacturer's manual for other inspection and maintenance activities. If you do not have a manual for the receiver, call 4-Star Trailers at 405-324-7827 for assistance.

If you see or can feel evidence of wear, such as flat spots, pitting or corrosion, on the ball or receiver, immediately have your dealer inspect them to determine the proper action to prevent possible failure of the ball and receiver system.

When replacing a ball, the load rating must match or exceed the GVWR of the trailer.

9.2.6.3. Gooseneck Fifth Wheel and Kingpin

Before each tow, inspect the fifth wheel and kingpin for wear, and coat the contact surface of the fifth wheel plate with water-resistant Lithium-base grease. If you see evidence of wear on the fifth wheel or kingpin, immediately have your dealer inspect them to determine the proper action to prevent failure of the fifth wheel and kingpin system.

See the manual prepared by the manufacturer of the fifth wheel and kingpin for other inspection and maintenance activities. If you do not have this manual, call 4-Star Trailers at 405-324-7827 for assistance.

9.2.7 Landing Leg or Jack

If a grease fitting is present, you must use a grease gun to lubricate the jack mechanism. Grease the gears in the top of hand-cranked jacks once a year, by removing the top of the jack and pumping or hand packing grease into the gears.

9.2.8 Lights and Signals

Before each tow, check the trailer taillights, stoplights, turn signals and any clearance lights for proper operation.

^WARNING

Improper operating taillights, stoplights and turn signals can cause collisions.

Check all lights before each tow.

9.2.9 Accessory Battery

Your trailer may be outfitted with an accessory battery that operates lighting, electric landing gear, slide-outs or other accessories. An accessory battery may be kept charged either by the tow vehicle or by the

generator or shore power. See the manual for the accessory battery.

A disconnect switch may be provided to disconnect the accessory battery when you do not plan to be using the trailer for an extended period, such as seasonal storage. If there is no disconnect switch, then remove the cables from the battery terminals.

The accessory battery must be kept in a charged condition during storage. The battery could freeze and break if it becomes discharged.

9.2.10 Tires

Trailer tires may be worn out even though they still have plenty of tread left. This is because trailer tires have to carry a lot of weight all the time, even when not in use. It is actually better for the tire to be rolling down the road than to be idle. During use, the tire releases lubricants that are beneficial to tire life. Using the trailer tires often also helps prevent flat spots from developing.

The main cause of tire failure is improper inflation. Check the cold tire inflation pressures at least once a week for proper inflation levels. "Cold" means that the tires are at the same temperature as the surrounding air, such as when the vehicle has been parked overnight. Wheel and tire manufacturers recommend adjusting the air pressure to the trailer manufacturer's recommended cold inflation pressure, in pounds per square inch (PSI) stated on the vehicle's Federal Certification Label or Tire Placard when the trailer is loaded to its gross vehicle weight rating (GVWR). If the tires are inflated to less than the recommended inflation level or the GVWR of the trailer is exceeded, the load carrying capacity of the tire could be dramatically affected. If the tires are inflated more than the recommended inflation level, handling characteristics of the tow vehicle/trailer combination could be affected. Refer to the owner's manual or talk to your dealer or vehicle manufacturer if you have any questions regarding proper inflation practices.

Tires can lose air over a period of time. In fact, tires can lose 1 to 3 PSI per month. This is because molecules of air, under pressure, weave their way from the inside of the tire, through the rubber, to the outside. A drop in tire pressure could cause the tire to become overloaded, leading to excessive heat build up. If a trailer tire is under-inflated, even for a short period of time, the tire could suffer internal damage.

High speed towing in hot conditions degrades trailer tires significantly. As heat builds up during driving, the tire's internal structure starts to breakdown,

compromising the strength of the tire. It is recommended to drive at moderate speeds.

Statistics indicate the average life of a trailer tire is about five years under normal use and maintenance conditions. After three years, replacing the trailer tires with new ones should be considered, even if the tires have adequate tread depth. Some experts claim that after five years, trailer tires are considered worn out and should be replaced, even if they have had minimal or no use. This is such a general statement that it may not apply in all cases. It is best to have your tires inspected by a tire supplier to determine if your tires need to be replaced.

If you are storing your trailer for an extended period, make sure the tires are fully inflated to the maximum rated pressure and that you store them in a cool, dry place, such as a garage. Use tire covers to protect the trailer tires from the harsh effects of the sun.

^WARNING

Worn, damaged or under-inflated tires can cause loss of control, resulting in damage, serious injury and possibly death.

Inspect tires before each tow.

9.2.11 Wheel Rims

If the trailer has been struck, or impacted, on or near the wheels, or if the trailer has struck a curb, inspect the rims for damage (i.e. being out of round); and replace any damaged wheel. Inspect the wheels for damage every year, even if no obvious impact has occurred.

9.2.12 Wheel Bearings

A loose, worn or damaged wheel bearing is the most common cause of brakes that grab.

To check your bearings, jack trailer and check wheels for side-to-side looseness. If the wheels are loose, or spin with a wobble, the bearings must be serviced or replaced.

Most trailer axles are built with sealed bearings that are not serviceable. Sealed bearings must be replaced as complete units.

Refer to the manual provided by the axle manufacturer for wheel bearing service information.

9.2.12.1. Unsealed Bearings (Hubs)

If your trailer has unsealed axle bearings, they must be inspected and lubricated once a year or 12,000 miles to insure safe operation of your trailer.

If a trailer wheel bearing is immersed in water, it must be replaced.

If your trailer has not been used for an extended amount of time, have the bearings inspected and packed more frequently, at least every six months and prior to use.

Refer to the manual provided by the axle manufacturer for wheel bearing service information.

9.2.13 Lug Nuts (Bolts)

Being sure wheel mounting nuts (lug nuts) on trailer wheels are tightened to the properly torque value is an important responsibility that trailer owners and users need to be familiar with and practice. Inadequate and/or inappropriate wheel nut torque (tightness) is a major reason that lug nuts loosen in service. Loose lug nuts can rapidly lead to a wheel separation with potentially serious safety consequences.

Lug nuts are prone to loosen right after a wheel is mounted to a hub. When driving on a new or remounted wheel, check the lug nut tightness often during the first few hundred miles of the trailer's use, especially after the first 10, 25 and 50 miles of driving and before each tow thereafter.

^WARNING

Lug nuts are prone to loosen after initial installation, which can lead to death or serious injury.

Check lug nuts for tightness on a new trailer or when wheel(s) have been remounted after the first 10, 25 and 50 miles of driving.

^WARNING

Metal creep between the wheel rim and lug nuts will cause rim to loosen and could result in a wheel coming off, leading to death or serious injury.

Tighten lug nuts before each tow.

Tighten the lug nuts to the proper torque for the axle and stud size on your trailer to prevent wheels from

coming loose. Use a torque wrench to tighten the fasteners. The only way to be certain you have tightened the lug nuts to the proper torque is with a torque wrench.

Four-way wrenches, ratchets, and similar tools can be useful for short-term emergency repairs, but are not appropriate tools for adequately checking lug nut torque.

You must use a torque wrench to adequately indicate the torque that you are applying to the lug nut. Over-tightening will result in breaking the studs or permanently deforming the mounting stud holes in the wheels.

Keep a record of the date and approximate mileage when you check the lug nut torque. Note any lug nut that has lost torque. Investigate the reason(s) if the lug nut torque is not maintained after more than one re-torque application, because this indicates there is something wrong with the lug nuts, nut studs, wheels and/or hubs and must be corrected.

Contact your dealer or vehicle manufacturer immediately if you experience any persistent lug nut loosening or any other lug, wheel or axle problems.

In the event of a wheel separation incident, notify the vehicle manufacturer and dealer. Seek prompt professional assistance in assessing the trailer and its gear, and retain, but don't re-use involved lugs, wheels and studs. Don't repair or service the trailer yourself. Call a trained technician.

Remove all oil, paint and excess grease from mounting surfaces.

For factory installed aluminum wheels, tighten the lug nuts using the sequence in figure 9-1, to the correct torque value listed for your wheel size.

16" Aluminum Wheel

1/2"-20 Stud----- 90-100 lb/ft of torque.

9/16"-18 Stud----- 120-140 lb/ft of torque.

17.5" Aluminum Wheel

5/8"-18 Flange Nut----- 140-160 lb/ft of torque.

For factory installed steel wheels, refer to the axle manufacturer's manual for the lug nut tightening sequence and torque value for your trailer. If you do not have the manual for the axles, call 4-Star Trailers at 405-324-7827 for assistance.

Never install aftermarket wheels or lug nuts on your trailer. Use only original equipment wheels and lug nuts. Aftermarket wheels and lug nuts may not meet the load carrying requirements, pressure capacity and offset as the original equipment.

Never install aluminum wheels on hubs/studs that were designed for steel wheels. The stud length required for aluminum wheels is greater than that for steel wheels.

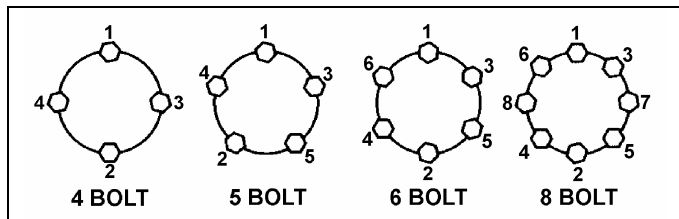

Wheel Lug Tightening Sequence – Figure 9-1